

# Cuisinart®

INSTRUCTION AND RECIPE BOOKLET



Premier Series 7-Cup Food Processor **DLC-2007NC**

For your safety and continued enjoyment of this product, always read the instruction book carefully before using.

**Recommended work bowl capacity for various foods**

FOOD	CAPACITY
Chopped Fruits and Vegetables	7 cups (1.75 L) processed food
Chopped or Puréed Meat, Poultry, Fish or Seafood	1-1/4 pounds (625 g) meat, cut in 1 inch (2.5 cm) or smaller cubes, chilled
Bread Dough	4 cups flour (32 ounces [1 L]), yielding two 1-pound (454 g) loaves
Pizza Dough	3 cups (750 ml) flour (26 ounces [737 g]), yielding 3 12-inch (30 cm) pizzas
Nuts for Nut Butters	2-3 cups (500-750 ml) (10-15 ounces [284-425 g])
Sliced or Shredded Fruit, Cheese, or Vegetables	7 cups (1.75 L) (total processed volume varies by food)
Cake Batter	batter for three 8-inch (20 cm) layers
Cookie Dough	dough for about 50 cookies (2 pounds [907 g])
Thin Liquids (such as custard for quiche or cheesecake batter)	2 cups (500 ml)
Thick Liquids	5 cups (1.2 L)
Puréed Cooked Fruits and Vegetables	5 cups (1.2 L) cooked yields approximately 3-1/2 cups (875 ml) thick purée
Puréed Soft Fresh Fruits (berries, kiwis, peaches, etc.)	5 cups (1.2 L) fresh yields approximately 3-1/2 cups (875 ml) thick purée

# IMPORTANT UNPACKING INSTRUCTIONS

This package contains a Cuisinart® Premier Series 7-Cup Food Processor, and the standard parts for it:

Work bowl, work bowl cover, large and small pushers, dough blade, metal chopping/mixing blade, slicing disc, shredding disc, detachable disc stem for discs, spatula, how-to DVD and recipe/instruction book.

## CAUTION:

**THE CUTTING TOOLS HAVE VERY SHARP EDGES.** To avoid injury when unpacking the parts, please follow these instructions.

1. Place the box on a low table or on the floor next to the kitchen counter or table where you intend to keep the food processor. Be sure the box is right side up.
2. Remove the cardboard insert. You will see a rectangular block of plastic foam that holds the processor parts, each fitted into a cavity in the foam.
3. The Detachable Disc Stem for the discs (A) sits in a cavity in one corner of the foam block. Remove this first.
4. The Pusher Assembly, with large and small pushers, (B) sits in the adjacent cavity. Remove this next.

5. The Dough Blade (C) rests in a cavity on the opposite side of the foam block. Remove it from the foam.
6. The plastic Spatula (D) is on one long side of the foam block. Remove it next.
7. The Slicing Disc (E) is on the edge of one of the long sides of the foam block; the Shredding Disc (F) is on the other side. Slide them out WITH GREAT CARE; THE BLADES ARE VERY SHARP.
8. Lift out the DVD from its space on the foam block.
9. Lift out the foam block.
10. Remove the instruction/recipe book.
11. The housing base with work bowl, metal blade and cover are at the bottom of the box. The metal blade is loose in the work bowl beneath a foam insert. Do not reach into feed tube. Do not turn over work bowl without first removing metal blade. Remove work bowl cover by turning it clockwise and lifting.
12. Remove the base and bowl together by grasping the plastic bowl at the top with both hands and lifting the bowl straight up. Do not rotate the bowl clockwise on the base. This will cause the bowl to separate from the base.
13. Place the food processor on the counter or table. Remove foam cylinder insert from top of metal chopping blade. Read the

instructions thoroughly before using the machine.

14. Save the shipping cartons and plastic foam blocks. You will find them very useful if you need to repack the processor for moving or other shipment.

**Please watch the enclosed how-to DVD before using the food processor.**

**NOTE: Remember to return your completed product registration card with all information carefully filled out.**

**WHEN REMOVING BLADE: CAREFULLY REMOVE THE METAL BLADE BY GRASPING THE CENTER WHITE HUB AND LIFTING IT STRAIGHT UP. NEVER TOUCH THE BLADES, AS THEY ARE RAZOR SHARP.**

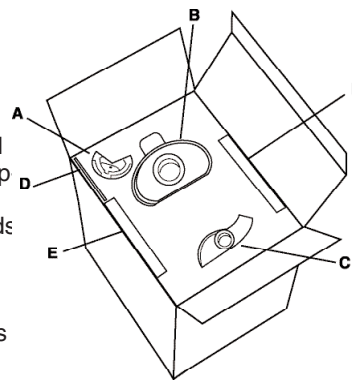

## TABLE OF CONTENTS

<b>Recommended Capacities</b> . . . . .	1	<b>Practicing Slicing and Shredding</b> . . . . .	12
<b>Unpacking Instructions</b> . . . . .	2	<b>Removing Sliced or Shredded Foods</b> . . . . .	12
<b>Important Safeguards</b> . . . . .	4	<b>Slicing and Shredding Techniques</b> . . . . .	12
<b>Introduction</b> . . . . .	5	Small, Round Fruits and Vegetables . . . . .	12
<b>Machine Includes</b> . . . . .	6	Long Fruits and Vegetables . . . . .	12
<b>Assembly Instructions</b> . . . . .	6	Small Amounts of Food . . . . .	13
<b>Machine Functions</b> . . . . .	7	French-Cut Green Beans . . . . .	12
<b>Operating Instructions</b> . . . . .	7	Matchsticks or Julienne Strips . . . . .	12
<b>Chopping, Puréeing &amp; Mixing</b>		<b>Slicing Meat and Poultry</b> . . . . .	13
<b>with Metal Blade</b> . . . . .	8	Cooked Meat and Poultry . . . . .	13
Chop Raw Fruits and Vegetables . . . . .	8	Uncooked Meat and Poultry . . . . .	13
Purée Fruits and Cooked Vegetables . . . . .	8	Slicing Sausages . . . . .	13
To Dislodge Food . . . . .	8	<b>Slicing and Shredding Cheese</b> . . . . .	13
Chop Hard Food . . . . .	8	<b>Kneading Yeast Dough</b>	
Chop Fresh Herbs . . . . .	8	<b>with Dough Blade</b> . . . . .	14
Chop Peel from Citrus Fruit . . . . .	8	Machine Capacity . . . . .	14
Chop Sticky Fruit Like Dates . . . . .	8	Using the Right Blade . . . . .	14
Chop Meat, Poultry and Fish . . . . .	9	Measuring the Flour . . . . .	14
Purée Meat, Poultry and Fish . . . . .	9	Proofing the Yeast . . . . .	14
Chop Nuts . . . . .	9	Processing Dry Ingredients . . . . .	14
Make Peanut Butter . . . . .	9	Adding Liquids . . . . .	15
Make Flavoured Butters,		Kneading Bread Dough . . . . .	15
Spreads and Dips . . . . .	9	Kneading Sweet Dough . . . . .	15
Make Mayonnaise . . . . .	9	Rising . . . . .	15
Beat Egg Whites . . . . .	10	Shaping, Finishing and Baking . . . . .	15
Whip Cream . . . . .	10	Making Consecutive Batches . . . . .	15
Make Crumbs and Crumb Crusts . . . . .	10	<b>Bread Dough</b>	
Make Pastry . . . . .	10	<b>Problems and Solutions</b> . . . . .	15
Make Quick Breads and Cakes . . . . .	10	<b>Sweet Dough</b>	
<b>Preparing Food For Slicing</b>		<b>Problems and Solutions</b> . . . . .	16
<b>and Shredding</b> . . . . .	11	<b>Cleaning and Storing</b> . . . . .	17
Round Fruits and Vegetables . . . . .	11	<b>For Your Safety</b> . . . . .	18
Whole Peppers . . . . .	11	<b>Technical Data</b> . . . . .	18
Large Fruits Like Pineapple . . . . .	11	<b>Warranty</b> . . . . .	18
Cabbage and Iceberg Lettuce . . . . .	11	<b>Recipes</b> . . . . .	20
Packing Feed Tube for			
Desired Results . . . . .	11		

Carefully read all instructions before using this appliance.

## IMPORTANT SAFEGUARDS

Always follow these safety precautions when using this appliance.

### Getting Ready

1. Read all instructions.
2. **Blades are sharp.**  
Handle them carefully.
3. Always unplug from outlet when not in use, before putting on or taking off parts, before removing food and before cleaning. To unplug, grasp plug and pull from electrical outlet. Never pull cord.
4. Do not use outdoors.
5. Do not let cord hang over edge of table or counter, or touch hot surfaces.
6. Do not operate any appliance with damaged cord or plug, or after appliance has been dropped or damaged in any way. Return appliance to the nearest authorized service facility for examination, repair, or electrical or mechanical adjustment.

### Operation

1. Keep hands as well as spatulas and other utensils away from moving blades or discs while processing food, to prevent the possibility of severe personal injury or damage to food processor. A plastic scraper may be used, but only

when the food processor motor is stopped.

2. Avoid contact with moving parts. Never push food down by hand when slicing or shredding. Always use pusher.
3. Make sure motor has completely stopped before removing cover. (If machine does not stop within **4 seconds** after you remove the pusher assembly, call 1-800-472-7606 for assistance. Do not use the machine.)
4. Never store any blade or disc on motor shaft. To reduce the risk of injury, no blade or disc should be placed on the shaft except when the bowl is properly locked in place and the processor is in use. Store blades and discs as you would sharp knives, out of reach of children.
5. Be sure cover and feed tube are securely locked in place before operating food processor.
6. Never try to override or tamper with cover interlock mechanism.

### Cleaning

To protect against risk of electrical shock, do not put base in water or other liquid.

### General

1. Close supervision is necessary when any appliance is used by or near children.
2. Do not operate this, or any other motor-driven appliance, while under the influence of alcohol or other substances that

affect your reaction time or perception.

3. This food processor is CUL listed for household use. Use it only for food preparation as described in the accompanying recipe and instruction book.
4. The use of attachments not recommended or sold by Cuisinart may cause fire, electrical shock or personal injury, or damage to your food processor.
5. To avoid possible malfunction of work bowl switch, never store processor with pusher assembly in locked position.
6. Maximum rating of 5.0 amperes is based on attachment that draws greatest current. Other recommended attachments may draw significantly less current.

**NOTICE:** This appliance has a polarized plug (one blade is wider than the other). As a safety feature, this plug will fit in a polarized outlet only one way. If the plug does not fit fully in the outlet, reverse the plug. If it still does not fit, contact a qualified electrician. Do not attempt to defeat this safety feature.

## SAVE THESE INSTRUCTIONS FOR HOUSEHOLD USE ONLY

## INTRODUCTION

Congratulations on your purchase of the Cuisinart® Prep 7® Food Processor. This product is the ultimate food preparation tool, and it comes from the originator of the Canadian food processor, Cuisinart.

The Cuisinart® Prep 7® has all the elements of quality that Cuisinart is known for, including a powerful motor, the largest feed tube, and the longest warranty in the industry.

It also introduces a new feature that will set the industry standard:

- **The Cuisinart® Supreme® Wide Mouth Feed Tube**, which is more than two and a half times the size of any other available. Perfect for slicing whole fruits and vegetables.

This feature, plus the ability to use all of your existing Cuisinart specialty blades and discs, make the Prep 7® the select choice in food processors.

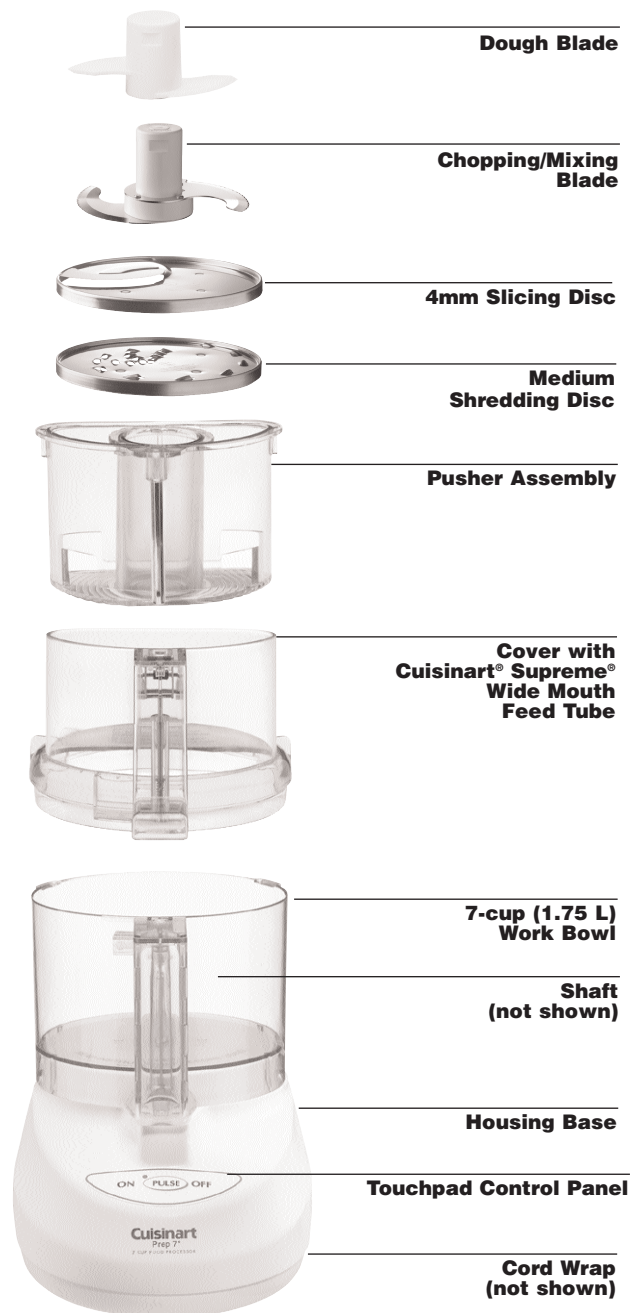

## THE MACHINE INCLUDES:

1. Housing base with a vertically projecting shaft and convenient touchpad control panel.
2. 7-cup (1.75 L) work bowl.
3. Cover with extra large feed tube.
4. Pusher assembly that slides inside the feed tube.
5. Dough blade.
6. Sharp metal chopping/mixing blade.
7. Serrated slicing disc.
8. Shredding disc.
9. Detachable stem for discs (not shown).
10. Plastic spatula (not shown).

The metal chopping blade chops raw and cooked fruits, vegetables, meat, fish and cheese to the exact consistency you want, from coarse to fine, even to a purée. It chops nuts, makes nut butters, mayonnaise and sauces, and mixes tender, flaky pastry. The metal chopping blade also mixes cakes, frostings, cookies, quick breads, muffins, and biscuits.

The slicing disc makes beautiful whole slices without torn edges. It slices whole fruits and vegetables, cooked meat, semi-frozen raw meat and loaves of bread.

The shredding disc processes most firm and

hard cheeses into long, attractive shreds. It also shreds vegetables like potatoes, carrots and zucchini, and processes nuts and chocolate to a grated texture.

The detachable stem fits both discs, making disc storage compact in limited space.

The pusher assembly has two parts.

1. A small, removable, clear pusher that fits into a small centre-located feed tube. This tube is for narrow food like carrots, for adding liquid, and for continuous feeding of small food like garlic.
2. A large pusher that fits into the Cuisinart® Supreme® feed tube opening and moves freely within it.

Upon contact, the large pusher meets an activating rod in the centre of the work bowl handle, permitting the motor to start.

## ASSEMBLY INSTRUCTIONS:

### Blade Operation

1. Plug in the housing base and place the work bowl on top, with the work bowl handle just to the left of centre. Turn the work bowl counterclockwise to lock it onto the housing base.
2. CAREFULLY lift and place the chosen blade over the work bowl centre hub. Line up the markings on the blade hub with the motor shaft.

Blade should fit snugly and rest on the bottom of the work bowl.

3. Add desired ingredients to work bowl.
4. Place work bowl cover onto work bowl, with the handle area just to the left of centre. Turn counterclockwise to lock onto work bowl.
5. Align pusher assembly and activating rod with the feed tube opening on the work bowl cover and slide the activating rod down to the bottom.
6. You are now ready to operate the machine.

### Disc Operation

1. Plug in the housing base and place the work bowl on top, with the work bowl handle just to the left of centre. Turn the work bowl counterclockwise to lock it onto the housing base.
2. Choose desired disc and place underside-up on tabletop. Pick up detachable disc stem and align it with the raised plastic crescent on the disc underside. The raised 'lock' indicator on the left corner of the stem should be to the left of the mounting plate on disc.
3. Turn the stem to the right, so the locking tabs are covered by the metal supports and a 'click' locks the stem in place.
4. With the stem facing down, place the assembly over the centre hub. It should fit snugly and rest on the bottom of the work bowl.

5. Place work bowl cover onto work bowl, with the handle area just to the left of centre. Turn counterclockwise to lock onto work bowl.
6. Align pusher with the feed tube opening on the work bowl cover and slide the activating rod down to the bottom.
7. Use the cord wrap on the housing base underside to add or remove cord.
8. You are now ready to operate the machine.

## THE MACHINE FUNCTIONS:

### PULSE

1. With the machine properly assembled and engaged, and ingredients in the work bowl, press the PULSE button repeatedly as needed.

### ON (Continuous)

1. Properly assemble and engage the machine.
2. To add ingredients through the feed tube, remove the pusher and fill the feed tube as directed (see preparing for slicing or shredding).
3. Engage the pusher and press the ON button. The button light will turn on and the motor will start.
4. Press the pusher firmly down until all ingredients have passed into the work bowl. Remove the pusher and refill ingredients as needed. When you engage the

pusher again, the unit will automatically turn ON.

5. Press the OFF button when finished.

## OPERATING INSTRUCTIONS:

Try chopping some practice foods, such as a zucchini or potato, before you process food to eat. First, cut the ingredients into 1-inch (2.5 cm) pieces.

- Place the work bowl over the centre stem and turn counterclockwise to lock in place.
- Insert the metal chopping blade and put ingredient pieces in the work bowl. Put on the cover and turn counterclockwise to lock onto work bowl. Align the pusher and the pusher's activating rod with the corresponding openings on the feed tube, and push all the way down.
- Press and release the PULSE button two or three times. Each time the blade stops, let the pieces drop to the bottom of the bowl before you pulse again. This puts them in the path of the blade each time the motor starts.
- Using the pulse/chopping technique, you get an even chop without overprocessing. Check the texture frequently by looking through the cover. If you want a finer chop, press and release the PULSE button until you achieve the desired texture. Onions and other food with a high water content will quickly end up as a purée, unless

examined through the work bowl after each pulse to make sure they are not overprocessed.

Try chopping other food like meat for hamburger or sausage. Then make mayonnaise, pastry or bread, as described in the following sections. To obtain consistent results:

Be sure all the pieces you add to the bowl are about the same size.

Be sure the amount you process is no larger than recommended on the inside cover of this booklet.

Before you do anything, wait for the blade to stop spinning. Once it does, turn the cover clockwise to unlock and remove by lifting it off.

Remove the bowl from the base of the machine before removing the blade. This creates a seal to prevent food from leaking. Turn the bowl clockwise to unlock from the base, and lift straight up to remove.

**To prevent the blade from falling from the work bowl onto your hand when emptying the work bowl, use one of the following methods.**

Be sure your hands are dry.



Grab the blade hub, and remove the metal blade before tilting the bowl, using a spatula to scrape off any food. Then carefully lift the blade out of the work bowl. Or insert your finger through the hole in the bottom of the work bowl, gripping the blade from the bottom, and grip the outside of the work bowl with your thumb. Or hold the blade in place with your finger or spatula while pouring out food.

## **TECHNIQUES FOR CHOPPING AND PURÉEING WITH THE METAL BLADE**

### **To chop raw fruits and vegetables:**

First cut the food into 1-inch (2.5 cm) pieces. You get a more even chop when all pieces are about the same size.

Put no more than the recommended amount of food into the work bowl (see table inside front cover). Lock the cover in place. Press the PULSE button at the rate of 1 second on, 1 second off, until the food is coarsely chopped. For more finely chopped results, hold the PULSE button, letting the machine run continuously until the desired consistency is reached. Check frequently to avoid overprocessing. Use the spatula to scrape down the sides of the work bowl if necessary.

### **To purée fruits and cooked vegetables:**

First, cut the food into 1-inch (2.5 cm) pieces.

You get a smoother purée faster when all pieces are about equal in size.

Put no more than the recommended amount of food in the work bowl (see table inside front cover). Lock the cover in place. PULSE to chop coarsely, then press the ON button and process continuously until food is puréed. (NOTE: Cooked potatoes are an exception to this procedure. They develop a gluey texture when processed with the metal blade.)

When making soup, you will want to purée vegetables that have been cooked in liquid. Don't add the liquid to the work bowl, just the cooked vegetables; remove vegetables with a slotted spoon. They will purée faster and smoother without liquid. Then add just enough liquid to make the purée pourable, return to the soup liquid and stir to combine.

### **To dislodge food:**

Occasionally, a piece of food may become wedged between the blade and the work bowl. If this happens, unplug the machine, remove the cover, lift the blade out carefully and remove the wedged piece. Empty the bowl, reinsert the blade and lock the cover and pusher in place. Press the ON button and drop the food pieces through the small feed tube opening while the machine is running. After adding a cupful this way, add the remaining food to the bowl and process in the usual manner.

### **To chop hard foods:**

To chop hard food like garlic and hard cheese, assemble the unit, remove the small pusher, press the ON button and drop the food through the small feed tube while the machine is running.

Small foods like garlic can be dropped in whole. Large foods like hard cheese should be cut into 1-inch (2.5 cm) pieces. This method of processing minces garlic, shallots and onions. Hard cheese and coconut will have the same texture as if they had been hand grated.

**IMPORTANT:** Never try to process cheese that is too hard to cut with a knife. You may damage the blade or the machine.

### **To chop parsley and other fresh herbs:**

The herbs, the work bowl and the metal chopping blade must all be thoroughly clean and dry. Remove stems from herbs. Add leaves to bowl and process, using the PULSE button until chopped as fine as desired. The more herbs you chop at a time, the finer chop you can obtain. If completely dry when chopped, parsley and other herbs will keep for at least 4-5 days, stored in an airtight bag in the refrigerator. They may be frozen for months, stored in an airtight container or bag.

### **To chop peel from citrus fruit or to chop sticky fruit like dates or raisins:**

For citrus, remove only the peel with a vegetable peeler, not the white pith which is bitter tasting.

Cut the peel into lengths of 2 inches (5 cm) or less and process with 1/2 cup (125 ml) of granulated sugar until finely chopped. This may take 2 minutes or longer.

For sticky fruit like dates, raisins, prunes and candied fruit, first freeze the fruit for about 10 minutes. Add some of the flour called for in the recipe to the fruit. Use no more than 1 cup (250 ml) of flour for each cup of fruit.

**To chop meat, poultry, fish and seafood:**

The food should be very cold, but not frozen. Cut it into 1-inch (2.5 cm) pieces to ensure an even chop. Using the ON button, process no more than the recommended amount at one time (see table inside front cover). Press the PULSE button 3 or 4 times at a rate of 1 second on, 1 second off. If the food is not chopped fine enough, let the processor run continuously for a few seconds. Check the texture often to avoid overprocessing. Use a spatula to scrape food from the sides of the bowl as necessary.

**To purée meat, poultry, fish and seafood:**

Prepare the food as described above. Press the PULSE button until evenly chopped, then process continuously to the desired texture. Scrape the bowl with a spatula as needed.

Leave the purée in the work bowl and add eggs, cream and seasonings as called for by the recipe. Process to combine thoroughly.

Remember, you control texture by the length of time you process. By varying the processing time, you can get a range of textures suitable for hamburgers, hash, stuffed peppers, or smooth mousses.

**To chop nuts:**

Chop no more than the recommended amount at one time. Press and release the PULSE button and check frequently to avoid nuts clumping together in a nut butter. When a recipe calls for flour or sugar, add some to the nuts before you chop, about 1/2 cup (125 ml) for each cup of nuts. This allows you to chop the nuts as fine as you want without turning them into a nut butter. You can also chop nuts with a shredding or slicing disc. The optional Fine Shredding Disc is particularly good.

**To make peanut butter and other nut butters:**

Process up to the recommended amount of nuts. Using the ON button, let the machine run continuously.

After 1-1/2 to 2 minutes, the ground nuts will form a ball that will gradually smooth out. Scrape the sides of the bowl and continue processing until drops of oil are visible. Taste for consistency. The longer you process, the softer the butter. For chunk style, add a handful of nuts just after the ball of nut butter begins to smooth out. To make cashew butter, add a little bland vegetable oil. Processor nut butters contain no preservatives.

Store in refrigerator to keep from separating.

**To make flavoured butters, spreads and dips:**

Cut room temperature butter into tablespoon size pieces. Finely chop flavouring ingredients first, such as anchovies, cheese, herbs, etc. Be sure work bowl is clean and dry. Add small hard ingredients like garlic and hard cheese through the feed tube while machine is running. Next, add the butter and process using the ON button, until smooth. Add any liquid ingredients last, while the processor is running, and process just long enough to blend. Process ingredients for spreads and dips the same way. They should be at room temperature and cut into 1-inch (2.5 cm) cubes, or added by tablespoonfuls.

**To make mayonnaise:**

You can make foolproof homemade mayonnaise with your Premier Series 7-cup Food Processor. The work bowl and metal blade must be clean and dry.

Foods prepared with raw eggs may contain salmonella or other potentially harmful bacteria. Because egg yolks are a fine growth medium for bacteria, we recommend that you cook them for use in mayonnaise, Hollandaise sauce, Caesar salad dressing, chilled soufflés, chilled chifons, mousses and other recipes calling for raw egg yolks. For mayonnaise, we recommend using either the “cooked egg” mayonnaise on page 29, or using the following method with pasteurized liquid eggs.

For a “one egg” batch of basic mayonnaise made with pasteurized liquid eggs, place 1/4 cup (62 ml) pasteurized liquid eggs, 2 tablespoons (30 ml) wine vinegar or lemon juice, 1 teaspoon (5 ml) dry mustard, 1/2 teaspoon (2 ml) kosher salt and a pinch of ground white pepper in the work bowl. With the machine running, add 1/2 cup (125 ml) of vegetable oil to the small pusher and allow to slowly drip into the mixture while processing. After all the oil has dripped through, add another 1/2 cup of vegetable oil to the small pusher and allow to drip through. The mixture will form a thick emulsion. For variation, you may experiment with using flavoured vinegars, adding chopped fresh herbs, dry herbs, or roasted garlic to taste. To make your mayonnaise a little lighter, add some well-drained plain fat free yogurt to taste.

#### **To beat egg whites:**

The work bowl must be absolutely clean. Add 3 or more egg whites (up to 6 large egg whites) and press the ON button. Add about 1 teaspoon (5 ml) of lemon juice or vinegar for every egg white. Vinegar makes stiffer whites; its flavour is hardly detectable in cakes or soufflés. Continue processing until the egg whites hold their shape, about 1-1/2 to 2-1/2 minutes.

#### **To whip cream:**

Processor whipped cream holds its shape very well. It is good for decoration or as a topping; however, it will not whip to the light, fluffy

consistency obtained by methods that beat in more air. Chill the cream well before starting. Process continuously using the ON button, until it begins to thicken. Then add sugar as desired and continue processing, watching carefully for the desired consistency.

For consistently reliable results, add 2 tablespoons (30 ml) of nonfat dry milk for every cup of cream before whipping.

#### **To make crumbs and crumb crusts:**

Cut or break bread, crackers or cookies into 1-inch (2.5 cm) pieces and place in work bowl. Press the ON button and process continuously until they reach the desired texture. For seasoned crumbs, chop parsley or other fresh herbs with the crumbs. For buttered crumbs, process until the dry crumbs are of the desired texture, then dribble melted butter through the small feed tube opening while the machine is running. For crumb crusts, process crackers or cookies as described above. Add sugar, spices and butter, and cut into pieces as specified by your recipe. Process until well combined.

#### **To make pastry:**

Combine unbleached all-purpose flour, salt and pieces of very cold butter in the work bowl. Process to the consistency of cornmeal. Sprinkle evenly with the minimum amount of cold liquid in the recipe. PULSE 5 or 6 times. The

dough should begin to hold together when pressed. If it is still dry and crumbly, add more water – 1 teaspoon (5 ml) at a time – until the dough holds together easily. Do not let the dough form a ball in the processor or it will be overworked and tough. Form into a round disc, one inch (2.5 cm) thick, and wrap in plastic wrap. Refrigerate for 1 hour before using, or doublewrap and freeze for later use.

#### **To make quick breads and cakes that use baking powder and/or soda:**

The most important rule for success is not to overmix after adding the flour. The ingredients for these soft doughs should be cold, except butter. If the recipe calls for chopped ingredients like lemon peel or nuts, chop them first while the work bowl is clean and dry, then set aside until needed.

Put dry ingredients like flour, salt and leavening in the work bowl and process with the metal blade for 5 seconds to mix. Remove and reserve the dry ingredients.

Add the eggs and sugar to the work bowl and, using the ON button, process to mix, letting the machine run about 1 minute. Next, add butter at room temperature and cut into 1-inch (2.5 cm) pieces. Run machine continuously for a minute, until the butter is thoroughly mixed with the sugar and eggs. Then add flavouring and liquid – vanilla, spices, cocoa, etc. Process until mixed. Add the dry ingredients to the work bowl.

Process by pulsing, inspecting after each pulse. Stop pulsing as soon as the dry ingredients have almost disappeared into the batter. Overprocessing will cause quick breads and cakes to be tough. (If your recipe calls for ingredients that are to be coarsely chopped – like raisins or nuts – add them last with the mixed dry ingredients.)

**To make cake mix:**

Your food processor work bowl is large enough for the preparation of an 18.5-ounce (524 g) packaged cake mix.

Insert the metal blade and add the cake mix to the work bowl. Press the ON button and while the machine is running, add the eggs and liquid through the small feed tube and process for 5 seconds.

Scrape down the sides of the work bowl and process 1 minute more for maximum volume. Do not remove the metal blade.

Insert a finger into the underside of the blade from the bottom of the work bowl to hold the blade in place while emptying the batter.

**Tip:**

After emptying cake batter or puréed soup from the work bowl, replace the bowl on the motor base and PULSE once. Centrifugal force will spin the batter off the blade onto the sides of the work bowl. Remove the blade, and use the spatula to scrape any remaining batter from the bowl.

## PREPARING FOOD FOR SLICING AND SHREDDING

**For disc assembly instructions, refer to Assembly Instructions.**

**Round fruits and vegetables:**

Before processing onions, apples and other large, round fruits and vegetables, cut the bottom ends flat to make the food lie stable on the disc.

Place the food in the feed tube, flat side down, as far left as possible, to prevent it from tilting when being processed.

Choose fruits that are firm and not too ripe. Remove large hard pits and seeds from fruits before processing. Seeds from citrus fruits need not be removed. Remove the rind before slicing or shredding, if desired.

**Whole peppers are an exception:**

Remove the stem and cut the stem end flat. Remove the core and scoop out the seeds. Leave the end opposite the stem whole, to keep the structure stiff. This ensures round, even slices.

**Large fruits like pineapple:**

Cut the ends flat, cut in half, and either core or remove the seeds. If necessary, cut the halves into smaller pieces to fit the feed tube.

**Cabbage and iceberg lettuce:**

Turn the head on its side and

slice off the top and bottom, leaving a centre section about 3 inches (7.5 cm) deep. Remove the core, then cut in wedges to fit the feed tube. Remove the core from the bottom and

top pieces and cut into wedges to fit into the feed tube.

The optional 2mm and 1mm Slicing Discs are excellent for slicing cabbage for coleslaw.

If the fruit or vegetable doesn't fit, try inserting it from the bottom of the feed tube, where the opening is slightly larger.

**Pack the feed tube for desired results.**

For long slices or shreds, cut the food in feed tube widths and pack the pieces horizontally.

For small, round slices or short shreds from carrots, zucchini and other long vegetables, cut in feed tube heights and pack tightly upright.

Food should fit snugly, but not so tightly that it prevents the pusher from moving.

When slicing or shredding, always use the pusher.

**Never put your fingers or a spatula into the feed tube.**

Never push down hard on the pusher. Use light pressure for soft fruits and vegetables like bananas, mushrooms, strawberries and tomatoes, and for all cheese. Use medium pressure for most food: apples, celery, citrus fruit, potatoes and zucchini. Use

firm pressure for hard vegetables like carrots and yams.

## PRACTICING SLICING AND SHREDDING

1. Insert a slicing or shredding disc, put the cover on the work bowl and insert the food in the feed tube.
2. Slide the pusher into place, and apply pressure to the pusher while pressing down the PULSE button. Release the button as soon as the food is sliced or shredded.
4. You can load the feed tube repeatedly without removing work bowl cover.

Simply grasp the pusher and lift up. The pusher assembly will come off easily, leaving the cover and feed tube in place. Your other hand is free to reload the feed tube, and you do not need to re-press the ON button if it was previously selected.

## REMOVING SLICED OR SHREDDED FOOD

Before you do anything, wait for the disc to stop spinning. When it does, remove the pusher first. Unplug the unit, then hold the work bowl handle and turn it clockwise. Then lift; the work bowl and cover will come off together. Turn cover clockwise to unlock from work bowl. Lift, remove, invert and place on counter space.

### Remove the slicing or shredding disc.

Place two fingers under each side of the disc and lift it straight up. Place the disc on top of the inverted work bowl cover to minimize drips and spills.

## TECHNIQUES FOR SLICING AND SHREDDING

### Small, round fruits and vegetables:

For large berries, radishes and mushrooms, trim the bottom ends flat with a knife. Insert the food through the feed tube, standing each piece on a flat end. You can fill the tube to about 1 inch (2.5 cm) from the top.

The bottom layer gives you perfect slices for garnish.

If you want all the slices to be perfect, it's best to process one layer at a time.

### Long fruits and vegetables:

Trim foods like bananas, celery and zucchini by cutting them into pieces slightly shorter than the feed tube. Cut both ends flat. (Use a ruler as a guide, or the pusher assembly.)

Fill the feed tube with the pieces, standing them vertically and adding enough pieces so they are solidly packed and cannot tilt sideways as they are sliced or shredded.

### Small amounts of food:

Use the small feed tube and the small pusher. Remove the small pusher from the pusher assembly. Place the pusher assembly onto the

feed tube and press the sleeve all the way down.

Cut the food in lengths slightly shorter than the feed tube. If slicing one or two long, thin vegetables like carrots, push them to the far left. If you are slicing a few vegetables that are wide at one end and narrow at the other (carrots, celery or scallions) cut them in half and pack in pairs, alternating one wide end up, one narrow end up.

### French-cut green beans:

Trim fresh green beans to feed tube widths. Stack in the feed tube horizontally to about one inch (2.5 cm) from the top. Use the slicing disc, apply light pressure to the pusher and press the PULSE button until beans are sliced.

To make long, horizontal slices of raw zucchini or carrots, use the same procedure.

### Matchsticks or julienne strips:

Process the food twice – 'double slice' it. Insert large fruits or vegetables (potatoes, turnips, zucchini, apples) in the feed tube horizontally. Apply pressure to the pusher while pressing the PULSE button until the food is sliced. You will get long slices.

Remove the slices from the work bowl and reassemble. Reinsert them in the feed tube, wedging them in tightly. Slice them again. You will obtain long julienne strips. With the optional Square Julienne Disc, you can make square julienne strips in one operation.

## SLICING MEAT AND POULTRY

### Cooked meat and poultry:

The food must be very cold. If possible, use a piece of food just large enough to fit in the feed tube. To make julienne strips of ham, bologna or luncheon meat, stack slices, then roll or fold them double and stand upright in the feed tube, wedging in as many rolls as possible. This technique works better with square or rectangular pieces than with round ones.

### Uncooked meat and poultry:

Cut the food into pieces to fit the feed tube. Boneless, skinned chicken breasts will usually fit when cut in half crosswise. Wrap the pieces in plastic wrap and put them in the freezer. They are ready to slice when

they are easily pierced with the tip of a sharp knife, although semi-frozen and hard to the touch. Remove plastic wrap. Stand them in the feed tube, cut side down, and slice them against the grain, using firm pressure on the pusher. Or lay them flat in the feed tube, as many as will fit, and slice with the grain, using firm pressure.

### Salami and other sausages:

If the sausage is soft, freeze it until hard to the touch but easily pierced with the tip of a sharp knife. Hard sausages need not be frozen. Use the small feed tube if the sausage is thin enough to fit. Otherwise, cut the sausage into pieces to fill the large feed tube completely. Stand the pieces vertically, packing them tightly so they cannot

tilt sideways.

### Firm cheese like Swiss and Cheddar:

Cut the cheese into pieces to fit the feed tube. Put it in the freezer until semi-frozen, hard to the touch but easily pierced with the tip of a sharp knife. Stand the pieces in the feed tube and apply light pressure to the pusher.

**IMPORTANT:** Never try to slice soft cheese like mozzarella or hard cheese like Parmesan. You may damage the slicing disc or the food processor itself. You can successfully shred most cheeses except soft ones. The exception is mozzarella, which shreds well if thoroughly chilled. Hard cheeses like Parmesan shred well only at room temperature.

---

## SLICING AND SHREDDING CHEESE

TYPE OF CHEESE	CHOP/ PUREÉ	SHRED	SLICE
<b>Soft</b>			
Brie, Camembert, room temperature	yes	no	no
Mozzarella chilled 15-20 min in freezer	no	yes	no
Ricotta, room temperature	yes	no	no
Cottage, Cream	yes	no	no
<b>Semi-Soft</b>			
Blue, chilled	yes	yes	no
Fontina, chilled	yes	yes	no
Bel Paese, chilled	yes	yes	no
<b>Semi-Hard</b>			
Cheddar, chilled	yes	yes	yes
Monterey Jack, Longhorn, chilled	yes	yes	yes
Swiss, Jarlsberg, chilled	yes	yes	yes
Edam, Gouda, chilled	yes	yes	yes
Provolone, chilled	yes	yes	yes
<b>Hard, at room temperature</b>			
Parmesan, Romano, Locatelli	yes	yes	no
Pecorino, Asiago	yes	yes	no

\*Soft and semi-soft cheeses will purée; semi-hard and hard cheeses will chop.

Therefore, only attempt to slice or shred mozzarella when well chilled, and Parmesan when at room temperature.

## **TECHNIQUES FOR KNEADING YEAST DOUGH WITH THE DOUGH BLADE**

The Prep 7™ Food Processor is designed to mix and knead dough in a fraction of the time it takes to do it by hand. You will get perfect results every time if you follow these directions.

### **NEVER TRY TO PROCESS DOUGH THAT IS TOO STIFF TO KNEAD COMFORTABLY BY HAND.**

There are two general types of yeast dough. Typical bread dough is made with a flour mix that contains at least 50% white flour. It is uniformly soft, pliable and slightly sticky when properly kneaded.

It always cleans the inside of the work bowl completely when properly kneaded.

Typical sweet dough contains a higher proportion of sugar, butter and/or eggs than typical bread dough. It is rich and sticky and it does not clean the inside of the work bowl.

It requires less kneading after the ingredients are mixed. Although 30 seconds are usually sufficient, 60 to 90 seconds give better results if the machine does not slow down. Except for kneading,

the processing procedures are the same for both types of dough.

### **Machine capacity**

Recommended maximum amount of flour is 4 cups (1 L) of all-purpose flour or 2-1/2 cups (625 ml) of whole-grain flour. If a bread dough calls for more than the recommended amounts of flour, mix and knead it in equal batches. Do the same for sweet doughs that call for more than 3-1/2 cups (875 ml) of flour.

### **Using the right blade**

Use the dough blade when the recipe calls for more than 3-1/2 cups (875 ml) (17-1/2 ounces [496 g]) of flour. Use the metal chopping blade when a recipe calls for less than 3-1/2 (875 ml) cups of flour.

Because the dough blade does not extend to the outside rim of the work bowl, it cannot pick up all the flour when small amounts are processed.

### **Measuring the flour**

It's best to weigh it. If you don't have a scale, or the recipe does not specify weight, measure by the stir, scoop and sweep method. Use a standard, graduated dry measure, not a liquid measuring cup.

With a spoon or fork, stir the flour in its container. Do not measure flour directly out of the bag; it is too packed to get an accurate measure. With the dry measure, scoop up the flour so it overflows. With a spatula or knife, sweep excess flour back into the

container so the top of the measure is level. Do not pack flour into the dry measure.

### **Proofing the yeast**

The expiration date is marked on the package. To be sure your yeast is active, dissolve it in a small amount of warm liquid (about 1/3 cup [75 ml] for one package of dry yeast). The temperature of liquid used to dissolve and activate yeast must be between 105 and 115°F (40°C and 46°C). Yeast cells are not activated at temperatures lower than this and they die when exposed to temperatures higher than 130°F (54°C). If the recipe includes a sweetener like sugar or honey, add a teaspoon (5 ml) with the yeast. If no sweetener is called for, add a pinch, or add a pinch of flour. The yeast won't foam without it. Let the mixture stand until it foams, up to 10 minutes. If it does not foam, discard and begin again.

### **Processing dry ingredients**

Put the flour in the work bowl with all the other dry ingredients. If the recipe calls for herbs, oil or solid fats like butter, add them with the flour. Turn the machine on and let it run for about 20 seconds. (Cheese, nuts and raisins may be added with the dry ingredients or during the final kneading. To leave them almost whole, add them 5 seconds before you stop kneading. For a finer texture, add them sooner.)

### **Adding liquids**

All liquid should be added through the feed tube while the machine is running. Add liquid in a slow, steady stream, only as fast as dry ingredients absorb it. If liquid sloshes or splatters, stop adding it but do not turn off the machine. Wait until ingredients in bowl have mixed, then add remaining liquid slowly. Pour liquid onto dough as it passes under feed tube opening. Do not pour liquid directly onto bottom of bowl.

Follow the recipe carefully. It is important to add enough liquid to make the dough soft enough to knead. Kneading dough that is too stiff can strain the machine.

All liquid except that used to activate yeast should be cold, to minimize the possibility of overheating the dough. You must never knead a yeast dough to a temperature higher than 100°F (37°C). Doing so will slow or even prevent the action of the yeast.

### **Kneading bread dough**

Do not try to use the machine to knead dough that is too stiff to knead comfortably by hand. Doing so can strain the machine.

After the dough starts to clean the inside of the work bowl completely and forms a ball, process it for 60 seconds to knead it. Stop the machine and test the dough to be sure it's properly kneaded. Typical bread dough should have a soft, pliable texture and it should feel slightly sticky. Stretch

the dough with your hands to test it. If it feels hard, lumpy or uneven, continue processing until it feels uniformly soft and pliable. Make sure that the blade is firmly pressed back into place after removing the dough to test it.

### **Kneading sweet dough**

Process dough for at least 30 seconds after all the ingredients have been incorporated. It will not clean the inside of the work bowl. If necessary, scrape the bowl and process for 5 more seconds.

### **Rising**

Put the dough in a large, resealable lightly floured plastic bag. Squeeze out all the air and seal, allowing space for the dough to rise.

Or put the ball of dough in a large bowl coated with soft butter or vegetable oil. Roll the dough around to coat its entire surface. Cover it with a damp towel or a piece of oiled plastic wrap.

Let it rise in a warm, draft-free place, about 80°F (26°C). The rising time is usually about 1-1/2 hours but will vary from 45 minutes to several hours, depending on the type of flour and the humidity of the air. To test if the dough has risen enough, stick a finger in it. An indentation should remain. If it doesn't, let the dough rise more and test again.

When it has risen enough, punch the dough down.

### **Shaping, finishing and baking**

If you shape the dough in loaf pans, fill pans only half full. Let rise until dough is just slightly above the top of the pan. If shaping free-form loaves, let them rise on an oiled baking sheet until at least doubled in bulk.

### **Making consecutive batches**

You can make several batches of bread dough in a row. The motor in the Prep 7™ Food Processor is extremely efficient.

## **TYPICAL BREAD DOUGH: PROBLEMS AND SOLUTIONS**

### **If dough blade doesn't incorporate ingredients:**

Always start processor before adding liquid. Add liquid in slow, steady stream, only as fast as dry ingredients absorb it. If you hear liquid sloshing, stop adding it but do not turn off machine. Instead, wait until ingredients in work bowl have mixed, then add remaining liquid slowly. Pour liquid onto dough as it passes under feed tube; do not pour liquid directly onto bottom of work bowl.

### **Blade rises in work bowl:**

Blade may not have been pushed down as far as possible before processing started.

Excessively sticky dough can cause blade to rise even though it cleans inside of work bowl.



If dough feels very sticky, reinsert blade and immediately add 2 tablespoons (25 ml) flour through feed tube while machine is running.

**Dough doesn't clean inside of work bowl:**

- Amount of dough may exceed maximum capacity of your food processor. Remove half and process in 2 batches.
- Dough may be too dry. If it feels crumbly, add water, 1 tablespoon (15 ml) at a time, while machine is running, until dough becomes moist and cleans inside of work bowl. Wait 10 seconds between additions of liquid.
- Dough may be too wet. While machine is running, add 1 tablespoon (9 g) of flour. If necessary, add more, 1 tablespoon (9 g) at a time, until dough cleans inside of work bowl and forms a ball.
- Dough blade is intended only for recipes calling for at least 3-1/2 cups (875 ml) of flour (17-1/2 ounces) (496 g). If your recipe calls for less flour, remove metal dough blade and insert metal chopping blade. Always use metal chopping blade for recipes calling for less than 3-1/2 cups (875 ml) (496 g) of flour, such as pizza dough.

**Nub of dough forms on top of blade and does not become uniformly kneaded:**

Stop machine, carefully remove dough, divide into 3 pieces and redistribute evenly in work bowl. Continue processing until dough is uniformly soft and pliable.

**Dough feels tough after kneading:**

Divide dough into 2 or 3 pieces and redistribute evenly in bowl. Process 10 seconds or until uniformly soft and pliable.

**Soft dough or liquid leaks onto base of food processor:**

Always start processor before adding liquid and add liquid only as fast as dry ingredients absorb it.

**Motor stops:**

- Cover may have become unlocked.
- Power cord may have become unplugged.
- Excessive strain may have caused motor to overheat and stop. Wait for the motor to cool, 5-10 minutes. A safety protector in the motor prevents excessive overheating. If the motor stops, turn machine off. After 5-10 minutes, divide dough into 2 batches and complete processing. Pinch dough to make sure that it is not too stiff to knead comfortably by hand. If it is, add liquid,

1 teaspoon (5 ml) at a time, until dough is sufficiently moist to clean inside of bowl.

**Dough doesn't rise:**

We recommend you always test activity of yeast before using, by stirring it and adding at least 1/2 teaspoon (2 ml) sugar into about 1/3 cup (75 ml) warm liquid (105-120°F) (40-48°C). Within 10 minutes foam should develop, indicating yeast is active. Do not use dry yeast after expiration date on package.

Do not use warmer water, or overheat dough with excessive kneading, as it may kill the yeast cells. All other liquid should be cold.

Don't knead so long that dough becomes overheated. The ideal temperature for kneaded dough is 80°F (26°C); it should never exceed 100°F (37°C).

Let dough rise in draft-free environment of about 80-90°F (26-32°C).

Dough containing whole grain flour will take longer to rise than dough made of white flour only.

**Baked bread is too heavy:**

Next time, feel dough to be sure it is uniformly soft, pliable and slightly sticky before setting aside to rise. Let dough fully double in bulk in bowl or bag, punch it down, then let it double again after it is shaped.

## PROBLEMS AND SOLUTIONS WITH TYPICAL SWEET DOUGHS

### Motor slows down:

- Amount of dough may exceed maximum capacity. Remove half, and process in 2 batches.
- Don't process too long after all ingredients are incorporated. Rich doughs will give you good results after only 30 seconds of kneading.

### Blade doesn't incorporate ingredients:

Butter or margarine, if not melted, must be cut into tablespoon-size pieces before being added to work bowl.

### Dough blade rises in work bowl:

Blade may not have been pushed down as far as possible before processing started. Machine may be overloaded. Remove half of dough and process in 2 batches.

### Motor stops:

See comments under 'Typical Bread Dough' Problems and Solutions

### Dough doesn't rise:

See comments under 'Typical Bread Dough' Problems and Solutions

## CLEANING AND STORAGE

Keep your Food Processor ready to use on a kitchen counter. When not in use, leave it unplugged. Don't

leave it with the pusher assembly in the locked position; this could damage the on-off mechanism.

Store the blades and discs as you would sharp knives, out of the reach of children. The Disc and Blade Holders are optional accessories which offer safe and convenient storage.

All parts except the housing base are dishwasher safe, and we recommend washing them in the dishwasher. Insert the work bowl upside down. Remember to unload the dishwasher carefully wherever you place sharp blades and discs.

To simplify cleaning, rinse the work bowl, cover, pusher assembly and blade or disc immediately after use so food won't dry on them. Openings at the bottom of the large pusher provide drainage and make cleaning easy. If food lodges in the pusher, remove it by running water through it, or use a bottle brush.

If you wash blades and discs by hand, do it carefully. Avoid leaving them in soapy water where they may disappear from sight. To clean the metal blade, fill the work bowl with soapy water, hold the blade by its plastic centre and move it rapidly up and down on the centre shaft of the bowl. Use of a spray attachment is also effective. If necessary, use a brush.

The work bowl is made of Lexan® (plastic), which is shatter resistant and heat resistant. It should not be placed in a microwave

oven, as the aperture at the front of the pusher houses the metal rod that activates the motor.

**TIP:** When preparing a meal, make the dishes with the least amount of wet ingredients first. For example, make the bread first; then you don't need to wash the bowl before making the salad. In many cases, wiping the bowl with a paper towel between recipes is sufficient.

Chopping certain foods may scratch or cloud the work bowl. These foods include ice, whole spices, coffee beans and oils like wintergreen. If you like to prepare your own spice blends, you may want to keep a second bowl just for that purpose.

The housing base is made of a tough plastic with high impact resistance. Its smooth surface will look new for years. Keep a sponge handy as you work, and wipe spills from the base.

Four rubber feet on the underside keep the base from moving on most work surfaces when the machine is processing heavy loads. If the feet leave spots on the counter, spray them with a spot remover and wipe with a damp sponge. If any trace of the spot remains, repeat the procedure and wipe the area with a damp sponge and nonabrasive cleaning powder.

To clean the inside of the detachable stem, slide the stem release button on the side up as far as it will go

and hold it there as you run water through the stem.

**IMPORTANT:** Never store any blade or disc on the motor shaft. No blade or disc should be placed on the shaft except when the processor is about to be used.

## FOR YOUR SAFETY

Like all powerful electrical appliances, a Premier™ Series Food Processor should be handled with care. Follow these guidelines to protect yourself and your family from misuse that could cause injury.

Handle and store metal blades and discs carefully. Their cutting edges are very sharp.

Always place discs on flat stable surface before connecting detachable stem.

Never put blades or discs on the motor shaft until the work bowl is locked in place.

Always be sure that the blade or disc is down on motor shaft as far as it will go.

Always insert chopping blade and dough blade in the work bowl before putting ingredients in bowl.

When slicing or shredding food, always use the pusher.

Never put your fingers or spatula into feed tube.

Always wait for the blade or disc to stop spinning before you remove the pusher assembly or cover from the work bowl.

Always unplug the unit before removing food, cleaning, or putting on or taking off parts.

Always remove work bowl from base of machine before you remove chopping blade or dough blade.

Be careful to prevent the chopping blade from falling out of the work bowl when emptying the bowl. Remove it before tilting bowl, or hold it in place with your finger, a spatula or a spoon.

## TECHNICAL DATA

The motor in your food processor operates on standard line operating current. The appropriate voltage and frequency for your machine are shown on a label under the base.

An automatic, temperature-controlled circuit breaker in the motor ensures complete protection against motor burnout. If the processor runs for an exceptionally long time when chopping, mixing or kneading a thick or heavy mixture in successive batches, the motor may overheat. If this happens, the processor will stop. Turn it off and wait for the motor to cool before proceeding. It will usually cool within 10 minutes.

In extreme cases, it could take an hour.

Safety switches prevent the machine from operating when the work bowl or the cover is not locked into position. The motor stops within seconds when the motor is turned off, and a fast-stop circuit stops it

instantly when the pusher assembly is removed.

Cuisinart® Premier Series offers a Three Year Limited Warranty on the Entire Machine.

## TEN YEAR FULL WARRANTY ON MOTOR.

This warranty supersedes all previous warranties on Cuisinart® Premier Series Food Processors.

This warranty is available to consumers only. You are a consumer if you are the owner of a Cuisinart® Premier Series Food Processor that was purchased at retail for personal, family or household use. This warranty is not available to retailers or other commercial purchasers or owners.

We warrant that your Cuisinart® Premier Series Food Processor will be free of defects in material or workmanship under normal home use for three years from the date of original purchase.

We warrant that the motor for your Cuisinart® Premier Series Food Processor will be free of defects in material or workmanship under normal home use for ten years from the date of original purchase. This motor warranty covers the motor and excludes all other parts in the motor base assembly area such as the upper and lower plastic housings, work bowl and cover, blades and all electrical components and vertical projecting motor shaft sheath.

We suggest you complete and return the enclosed warranty registration card promptly to facilitate verification of original purchase date. However, return of the warranty registration card is not a condition of this warranty. In the event that you do not have proof of purchase date, the purchase date for purposes of this warranty will be the date of manufacture.

If your Cuisinart® Premier Series Food Processor should prove to be defective within the warranty period, we will repair it, or if we think necessary, replace it, without charge to you. To obtain warranty service, simply call our toll-free number 1-800-472-7606 for additional information from our Customer Service Representatives or send the defective product to Customer Service at Cuisinart, 156 Parkshore Drive, Brampton, Ont. L6T 5M1

To facilitate the speed and accuracy of your return, please also include \$10.00 for shipping and handling of the product. Please also be sure to include a return address, description of the product defect, product serial number and any other information pertinent to the product's return. Please pay by cheque or money order.

**NOTE:** For added protection and secure handling of any Cuisinart® product that is being returned, we recommend you use a traceable, insured delivery service. Cuisinart cannot be held responsible for in-transit damage or for packages that are not delivered to us. Lost and/or damaged products are not covered under warranty.

If the problem with the machine is determined to be a defect of the motor, and within the warranty period, all postage and handling charges will be refunded.

Please be sure to include your return address, daytime phone number, description of the product defect, product serial number, original date of purchase, and any other information pertinent to the product's return.

Your Cuisinart® Premier Series Food Processor has been manufactured to the strictest specifications and has been designed for use with the authorized accessories and replacement parts.

This warranty expressly excludes any defects or damages caused by accessories, replacement parts, or repair service other than those that have been authorized by Cuisinart.

This warranty excludes all incidental or consequential damages.

**Warning:**

Our Premier™ Series Food Processor, and other Cuisinart Food Processors and Accessories have been carefully designed and manufactured with the highest quality materials to assure your satisfaction and safety when you use them. Although accessories sold by companies other than Cuisinart may be compatible with your Cuisinart machine, they may also be extremely dangerous, and expose the user to serious injury.

We specifically caution you not to use other brand accessories, such as

juicers, which permit your machine to operate with exposed cutting or shredding discs. We also caution you not to use the large feed tube on this machine with machines built by other manufacturers.

If you have any questions about the safety features of Cuisinart® Premier Series Food Processor or any other Cuisinart product, please call us at the toll-free number above.

# Recipe Table of Contents

 <b>Appetizers</b> .....	21
 <b>Soups</b> .....	23
 <b>Breads</b> .....	25
 <b>Sauces and Dressings</b> .....	29
 <b>Entrées</b> .....	33
 <b>Pizza</b> .....	36
 <b>Sides</b> .....	37
 <b>Desserts</b> .....	41

## Recipe Notes:

Preparation times are estimates and are based on the time it takes to prepare, assemble, and cook the ingredients once they have been gathered from the refrigerator and cupboard and placed on the counter.

Nutritional analyses are based on number of servings indicated. If a recipe produces a range of servings, they are based on the highest serving yield for that particular recipe.



# Appetizers

## Fresh Tomato and Corn Salsa

Delicious with the traditional corn tortilla chips, this salsa is also great on grilled chicken or seafood.

Makes 1-1/2 cups (375 ml)

1	small onion, peeled, cut into 1-inch (2.5 cm) pieces (about 1/2 cup [125 ml] pieces)	1	teaspoon (5 ml) fresh lime juice
		1/2	cup (125 ml) fresh or frozen corn kernels (frozen kernels do not need to be thawed)
1/4	cup (50 ml) fresh cilantro		
1	medium jalapeño pepper, seeded, cut into 1 inch (2.5 cm) pieces	1/2	teaspoon (2 ml) kosher salt
2	medium vine ripened tomatoes, cut into 1-inch (2.5 cm) pieces		

Place onion, cilantro and jalapeño in work bowl fitted with the metal blade. Process until finely chopped, about 5 seconds. Scrape work bowl. Add tomatoes and lime juice. Pulse until tomatoes are coarsely chopped, about 5 to 7 times. Add corn and salt; pulse once to just combine. Let stand for 1 hour before serving to allow flavours to develop. Serve with chips.

Preparation: 5 – 10 minutes, plus 1 hour for flavours to develop

Nutritional analysis per tablespoon (15 ml):

Calories 18 (10% from fat) • carb. 4g • pro. 1g • fat 0g • sat. fat 0g  
chol. 0mg • sod. 50mg • fiber 0g

## Hummus

Serve this popular Middle Eastern sauce with the traditional pita wedges or as a dip for fresh vegetable crudité's.

Makes 2 cups (500 ml) /32 tablespoons (480 ml)

1/4	cup (50 ml) Italian parsley leaves, washed and dried	3	tablespoons (45 ml) tahini
		2	tablespoons (25 ml) fresh lemon juice
2	strips lemon zest, 2 x 1/2 inches (5 x 1.25 cm), bitter white pith scraped off	5	tablespoons (75 ml) water
		1-1/2	teaspoons (7 ml) ground cumin
1/2	teaspoon (2 ml) kosher salt	1-1/2	tablespoons (25 ml) extra virgin olive oil
2	small cloves garlic		
1	large can (28 - ounce [794 g]) chickpeas, drained, rinsed and drained again		

Insert the metal blade. Use the pulse to chop the parsley, 10 to 15 times. Remove and reserve. Chop the lemon zest with the kosher salt using the pulse, 10 times. With the machine running, drop the garlic down the feed tube; process 10 seconds to chop. Add the drained chickpeas, tahini, lemon juice, water, and cumin to the work bowl; process 60 seconds to combine. Scrape the work bowl. With the machine running, add the olive oil in a slow steady stream; process until the hummus is smooth and creamy, about 3 minutes. Add half the chopped parsley; pulse to incorporate, 5 to 10 times. Allow the hummus to rest for 30 minutes before serving to allow the flavours to blend. Serve in a shallow bowl, sprinkled with the remaining chopped parsley. If desired, drizzle with extra virgin olive oil.

Variation: Add 3 drained roasted red peppers with the chickpeas to make Roasted Red Pepper Hummus. Makes about 2-1/2 cups (625 ml).

Preparation: 15 to 20 minutes, plus 30 minutes resting time

Nutritional analysis per tablespoon (15 ml):  
roasted red pepper hummus

Calories 45 (33% from fat • carb. 6g ) • pro. 2g • fat 2g • sat. fat 0g  
chol. 0mg • sod. 112mg • fiber 1g

## Jalapeño Jack Wafers

These savoury wafers just melt in your mouth.

Makes 40 wafers

6	ounces (170 g) Monterey Jack cheese	1	ounce (28 g) onion, cut into 1/2-inch (1.25 cm) pieces
1	small fresh jalapeño, stemmed and seeded	3/4	cup (175 ml) all-purpose flour
3	tablespoons (45 ml) unsalted butter		kosher salt for sprinkling, optional
3/4	teaspoon (3 ml) dry cilantro		

Insert shredding disc. Place cheese in large feed tube and shred using light pressure; remove and reserve. Remove shredding disc and insert metal blade. Add jalapeño and onion; process until coarsely chopped, about 5 to 10 seconds. Scrape work bowl. Add shredded cheese, butter and cilantro. Process until well blended and forms a ball, about 20 seconds. Scrape sides of work bowl. Add flour and process until dough forms a ball, about 10 to 15 seconds.

Turn dough out onto plastic wrap and shape into a log approximately 10 inches (25 cm) long. Wrap in plastic wrap and chill 30 minutes before using. May be made ahead to this point and refrigerated up to 3 days before using.

Preheat oven to 350°F (177°C). Slice logs into 1/4-inch (0.625 cm) pieces. Place on an ungreased baking sheet and sprinkle lightly with kosher salt if desired. Bake until lightly browned on the bottom and edges, about 20 minutes. Cool on wire rack before serving.

Preparation: 10 – 15 minutes, plus 30 minutes resting time, 30 minutes baking and cooling

Nutritional analysis per wafer:

Calories 33 (60% from fat) • carb. 2g • pro. 1g • fat 2g  
sat. fat 1g • chol. 7mg • sod. 26mg • fiber 0g

# Soups

## Vegetarian Potato and Split Pea Soup

Hearty enough to serve for supper, this soup has only 3 fat grams per serving!

Makes six 6-ounce (170 g) servings

1	small carrot, peeled, cut to fit feed tube vertically	2-1/3	cups (583 ml) water
1	small celery rib, peeled, cut to fit feed tube vertically	1-1/2	cups (375 ml) reduced fat, low-sodium vegetable broth
1	small onion, peeled, cut in half	1	small potato (about 5 ounces [142 g])
1-1/2	tablespoons (25 ml) unsalted butter	1/2	pound (227 g) split green peas, rinsed and sorted
1	small garlic clove, peeled	1/4	teaspoon (1 ml) ground black pepper

Insert the 4 mm slicing disc. Slice the carrot, celery, and onion using medium pressure; reserve.

Melt butter in a 3-3/4 - quart (3.5 L) saucepan over medium heat. Add carrot, celery, onion and garlic. Cook until soft, about 10 to 15 minutes. Add water and broth; cover and bring to a boil over medium-high heat. Peel potato and cut into 1-inch (2.5 cm) pieces. Add potato and split peas to saucepan. Reduce heat to low and simmer, partially covered, until peas and potatoes are tender, about 30 minutes. Remove from heat and cool for 10 minutes. Drain liquid from vegetables, being sure to reserve liquid in a large saucepan.

Insert metal blade. Process half of vegetables until smooth, about 15 to 20 seconds. Return to saucepan with liquid and repeat with remaining vegetables. Rewarm over low heat. Season with pepper.

Preparation: 20 minutes, plus 45 minutes to cook and finish

Nutritional analysis per serving:

Calories 178 (16% from fat) • carb. 30g • pro. 9g • fat 3g  
sat. fat 2g • chol. 8mg • sod.412mg • fiber 6g



## Gazpacho

Always served well chilled, this refreshing summer favourite has its origins in the Andalusian region of Spain.

Makes four 8-ounce (227 g) servings

1	garlic clove, peeled	2-1/3	cups (583 ml) tomato juice
1	small jalapeño pepper, seeded, cut into 1-inch (2.5 cm) pieces	1	small cucumber, peeled, cut in half lengthwise, seeds removed
1/4	cup (50 ml) fresh cilantro	2	tablespoons (25 ml) + 1 teaspoon (5 ml) fresh lime juice
4	small scallions, trimmed, cut into 1-inch (2.5 cm) pieces	1/4	teaspoon (1 ml) coarsely ground black pepper
1/2	green bell pepper, cored, seeded, cut into 1-inch (2.5 cm) pieces	1/8	teaspoon (0.5 ml) kosher salt
2	medium tomatoes, cored, cut into 1-inch (2.5 cm) pieces	4	teaspoons (20 ml) reduced fat sour cream fresh cilantro sprigs for garnish

Insert metal blade and process garlic and jalapeño until finely chopped, about 5 seconds. Scrape bowl. Add cilantro, scallions and green pepper; pulse to coarsely chop, about 8 to 10 times. Transfer to a large mixing bowl. Place tomatoes in work bowl and pulse to coarsely chop, about 8 times. Do not overprocess. Transfer to mixing bowl. Add tomato juice to tomato mixture and stir to combine.

Insert 4mm slicing disc. Place cucumber in feed tube vertically and slice using medium pressure. Add to mixing bowl. Add lime juice, pepper and salt and stir to combine. Cover tightly with plastic wrap and refrigerate to chill before serving. Serve garnished with 1 teaspoon (5 ml) sour cream and a fresh cilantro sprig.

Preparation: 15 – 20 minutes, plus chilling time

Nutritional analysis per serving:

Calories 72 (16% from fat) • carb. 16g • pro. 3g • fat 1g  
sat. fat 0g • chol. 2 mg • sod. 687mg • fiber 3g

# Breads

## Classic Cuisinart White Bread

Fresh homemade bread is simple to make with your Cuisinart Food Processor.

Makes 16 servings (2 loaves, 1 pound [454 g] each)

1	package active dry yeast	3	tablespoons (45 ml) unsalted butter, in 1-inch (2.5 cm) pieces
2	teaspoons (10 ml) sugar		
1/3	cup (75 ml) warm water (105 - 115°F [41-46°C])	1-1/2	teaspoons (7 ml) salt
		1	cup (250 ml) cold water
4	cups (1 L) unbleached all-purpose flour		Cooking spray

In a 2-cup (500 ml) liquid measure dissolve yeast and sugar in warm water. Let stand until foamy, about 5 minutes.

Insert dough blade. Process flour, butter and salt until combined, about 10 to 15 seconds. Add cold water to yeast mixture. With machine running, add liquid through small feed tube as fast as flour absorbs it. Once dough cleans the sides of the work bowl and forms a ball, process for 45 seconds to knead dough. Place dough in a lightly floured plastic food storage bag and seal the top. Allow to sit in a warm place until doubled in size, about 1 to 1-1/2 hours.

Spray two 8 x 4-inch (20 x 10 cm) loaf pans with vegetable oil cooking spray. Place dough on a lightly floured surface and punch down. Divide dough in half and roll each half into an 8 x 4-inch (20 x 10 cm) rectangle. Beginning with a short end, roll up the dough jellyroll fashion. Pinch the seam and ends tightly to seal. Place in prepared loaf pans and cover with plastic wrap coated with cooking spray. Let rise until dough is just above the tops of the pans, about 45 minutes to 1 hour. Fifteen minutes before baking, preheat oven to 400° F (204° C) .

Bake until tops are browned and loaf sounds hollow when tapped, about 30 to 35 minutes. Remove from pans and cool on wire rack.

Preparation: 10 – 15 minutes, plus 3 hours to rise and bake

Nutritional analysis per serving:

Calories 137 (17% from fat) carb. 25g • pro. 3g • fat 3g  
sat. fat 1g • chol. 6mg • sod. 221mg • fiber 1g

For Classic Cuisinart Wheat Bread, substitute 2 cups (500 ml) whole wheat flour for 2 cups (500 ml) of the white flour.

## Pecan Sticky Buns

Cuisinart Pecan Sticky Buns are so good that it is hard to eat just one!

Makes nine servings

### Sweet Dough:

- 1 package active dry yeast
- 1/4 cup (50 ml) warm water (105 - 115°F [41-46°C])
- 2-1/2 cups (625 ml) unbleached all-purpose flour
- 1/4 cup (50 ml) unsalted butter, in 1-inch (2.5 cm) pieces
- 1/4 cup (50 ml) sugar, divided
- 1/2 teaspoon (2 ml) salt
- 1/3 cup (75 ml) fat free milk
- 1 large egg
- Cooking spray

### Topping:

- 1/2 cup (125 ml) pecans
- 1/4 cup (50 ml) sugar
- 1/2 teaspoon (2 ml) cinnamon
- 1 tablespoon (15 ml) unsalted butter, softened
- 1/3 cup (75 ml) raisins
- 1/4 cup (50 ml) unsalted butter, melted
- 1/3 cup (75 ml) firmly packed light brown sugar

### To make dough:

In a 2-cup (500 ml) liquid measure dissolve yeast and 1 teaspoon (5 ml) sugar in warm water. Let stand until foamy, about 5 minutes. Place flour, butter, remaining sugar and salt in the work bowl fitted with the dough blade. Process to combine, about 20 seconds. Stir milk and egg into yeast mixture. With motor running, pour liquid mixture through the small feed tube as fast as the flour absorbs it. Process until dough cleans the sides of the work bowl, then process for 45 seconds to knead dough. Transfer to a plastic food storage bag and seal top. Let rise in a warm place until doubled in size, about 1-1/2 hours.

### To make topping / assemble buns:

Insert metal blade in work bowl and pulse to coarsely chop pecans, about 5 to 6 times. Reserve. Combine sugar and cinnamon; reserve. Transfer dough to a lightly floured surface and punch dough down. Roll into a 9 x 9-inch (22.5 x 22.5 cm) square. Spread with softened butter, sprinkle with cinnamon/sugar mixture and top with raisins. Roll dough up tightly and pinch seam to seal. Using a serrated knife, cut into 9 slices (about 1 inch [2.5 cm] thick).

Pour melted butter into a 9 x 9-inch (22.5 x 22.5 cm) baking pan. Sprinkle brown sugar and reserved pecans over butter. Place buns, cut side up, in pan. Cover with plastic wrap coated with vegetable oil cooking spray and let rise in a warm place for 40 minutes. Fifteen minutes before baking, preheat oven to 375° F (191° C).

Bake in preheated 375° F (191° C) oven until tops are well browned, about 30 minutes. Remove from oven and invert pan immediately onto serving plate, allowing sugar mixture to drip onto buns. Scrape any remaining sugar/nut mixture onto buns and serve warm.

Preparation: 25 – 30 minutes, plus 3 hours to rise and bake

### Nutritional analysis per serving:

Calories 374 (40% from fat) • carb. 52g • pro. 5g • fat 17g  
sat. fat 8g • chol. 55mg • sod. 148mg • fiber 2g

## Sesame Dinner Rolls

Fresh, warm rolls make any dinner extra special.

Makes 16 rolls

1/2	cup (125 ml) + 2 tablespoons (25 ml) evaporated fat free milk	6	tablespoons (90 ml) unsalted butter, in 1-inch (2.5 cm) pieces
1	package active dry yeast	1	teaspoon (5 ml) salt
1-1/2	tablespoons (25 ml) sugar		Cooking spray
1	large egg, beaten	1	large egg
2-3/4	cups (675 ml) unbleached all-purpose flour	1	teaspoon (5 ml) water
		1	teaspoon (5 ml) sesame seeds

In a small saucepan over medium heat, warm milk to 110 – 115°F (43 – 46°C) (Test temperature with an instant read thermometer.) Remove from heat. Add yeast and sugar; stir to dissolve and let stand until foamy, about 5 minutes. Add beaten egg; stir gently to combine. Transfer to a 2-cup (500 ml) liquid measure and reserve.

Use dough blade to process flour, butter and salt until combined, about 15 to 20 seconds. With machine running, add yeast mixture through the small feed tube in a steady stream as fast as the flour absorbs it. After the dough forms a ball, process 45 to 50 seconds to knead. Place in a large plastic food storage bag and seal top. Let rise until doubled in size, about 1 to 1-1/2 hours.

Lightly coat a 9-inch (22.5 cm) round baking pan with cooking spray. Place dough on a lightly floured surface and punch down. Divide dough into 16 equal pieces and shape each piece into a ball. Place balls into the pan so they are just touching each other. Cover with plastic wrap coated with vegetable oil cooking spray and let rise 1 hour. Fifteen minutes before baking, preheat oven to 350° F (177° C).

Combine egg and water. Brush over rolls and sprinkle with sesame seeds. Bake in preheated 350° F (177° C) oven until golden, about 35 to 40 minutes. Cool on wire rack.

Preparation: 20 minutes, plus 3 hours to rise and bake

Nutritional analysis per serving:

Calories 142 (35% from fat) • carb. 19g • pro. 4g • fat 5g  
sat. fat 3g • chol. 38mg • sod. 167mg • fiber 1g

## Basic Pizza Dough

Pizzas are so simple to make with a Cuisinart Food Processor that you can throw away the delivery menu!

Makes 3/4 - pound (340 g) dough to make two 9-inch (22.5 cm) crusts or one 14-inch (35 cm) crust

1	package active dry yeast	1-2/3	cups (400 ml) unbleached all-purpose flour or bread flour
1	teaspoon (5 ml) sugar	1	teaspoon (5 ml) extra virgin olive oil
2/3	cup (150 ml) warm water (105 – 115° F [41 – 46° C])	3/4	teaspoon (3 ml) salt

In a 2-cup (500 ml) liquid measure, dissolve yeast and sugar in warm water. Let stand until foamy, about 3 to 5 minutes. Insert metal blade in work bowl and add flour, olive oil and salt. Add cold water to yeast mixture.

With machine running, pour liquid through small feed tube as fast as flour absorbs it. Process until dough cleans sides of work bowl and forms a ball. Then process for 30 seconds to knead dough. Dough may be slightly sticky. Coat the dough lightly with olive oil, place in a plastic food storage bag and seal the top. Let rise in a warm place for about 45 minutes.

Place dough on a lightly floured surface and punch down. Roll into desired crust size(s) and follow pizza recipe.

Nutritional analysis per slice:

Calories 206 (7% from fat) • carb. 41g • pro. 6g • fat 2g  
sat. fat 0g • chol. 0mg • sod. 442mg • fiber 1g

## Cranberry – Orange Bread

Apples make this bread very moist – for a breakfast treat, slice and toast.

Makes 1 loaf (14 slices)

1-1/4 cups (300 ml) unbleached all-purpose flour	1	small apple (about 5 ounces [142 g] total), peeled, cored, cut into 1-inch (2.5 cm) pieces
1-1/2 teaspoons (7 ml) baking powder	1	large egg
1/4 teaspoon (1 ml) salt	1/2	teaspoon (2 ml) vanilla extract
3/4 cup (175 ml) pecan halves, shells removed	1/4	cup (50 ml) unsalted butter, melted
3 strips orange zest, bitter white pith removed	3	tablespoons (45 ml) buttermilk
2/3 cup (150 ml) sugar	1/3	cup (75 ml) plus 1 tablespoon (15 ml) dried cranberries

Preheat oven to 350°F (177°C). Lightly spray an 8 x 4-inch (20 x 10 cm) loaf pan with cooking spray. In a small bowl combine flour, baking powder and salt. Reserve. Insert metal blade and pulse to coarsely chop pecans, about 6 times. Remove and reserve.

Process orange zest and sugar until zest is finely chopped, about 45 seconds. Add apple, egg and vanilla; process until combined, about 15 to 20 seconds. With machine running, add butter and buttermilk through the small feed tube. Process until combined, about 10 to 15 seconds. Scrape the work bowl. Add cranberries, pecans and dry ingredients. Pulse until flour is just mixed in, about 5 to 6 times. Do not overprocess.

Transfer batter to prepared pan. Bake until golden brown and a toothpick inserted in the centre comes out clean, about 55 to 60 minutes. Cool in pan on a wire rack. Remove from pan and cool completely. For best results, wrap in plastic wrap and allow to rest for 24 hours before slicing.

Preparation: 10 – 15 minutes, 2 hours to bake and cool

Nutritional analysis per slice:

Calories 172 (43% from fat) • carb. 21g • pro. 2g • fat 8g  
sat. fat 3g • chol. 24mg • sod. 51mg • fiber 1g

# Sauces and Dressings

## Basic Mayonnaise

(The American Egg Board recommends using the freshest eggs and then heating them to kill salmonella bacteria. This recipe uses a procedure suggested by cookbook author and food sleuth Shirley Corriher for heating the eggs to sanitize them. The results are definitely worth the effort. Proper refrigeration and storage is necessary.)

Makes 1 cup (250 ml)

1	large egg	1/4	teaspoon (1 ml) flour
1	large egg yolk	2	teaspoons (25 ml) dry mustard
1-1/2	teaspoons (7 ml) freshly squeezed lemon juice	1/2	teaspoon (2 ml) kosher salt pinch of cayenne
1	teaspoon (5 ml) wine vinegar	2	tablespoons (25 ml) extra virgin olive oil
1	tablespoon (15 ml) water		
1/4	teaspoon (1 ml) sugar	3/4	cup (175 ml) vegetable oil

Insert the metal blade. Process the egg, egg yolk, lemon juice, wine vinegar, water, sugar and flour until smooth, about 20 seconds. Transfer the egg mixture to a small (7 or 8-inch [17.5 or 20 cm]) nonstick skillet, and heat over very low heat while gently stirring and scraping the bottom of the pan with a spatula. When the mixture begins to thicken and resemble a custard sauce, remove from the heat while still stirring and set in a pan of ice and water to stop mixture from cooking. Stir until the egg mixture is cooled; let rest for 5 minutes. Wash the work bowl, metal blade and lid in hot soapy water and dry thoroughly.

Insert the metal blade. Process the cooled egg mixture with the dry mustard, kosher salt, and cayenne until blended, about 1 minute. Scrape the work bowl. With the machine running, add the olive oil slowly, taking about 30 seconds to add the entire 2 tablespoons (25 ml). Scrape the work bowl. With the machine running, add the vegetable oil to the small pusher, one-quarter cup (50 ml) at a time, and allow the oil to drip slowly into the emulsion. The mayonnaise will thicken as the oil is added. Taste and adjust seasonings as necessary. Remove to a container, cover, and keep refrigerated. Keeps 3 to 4 days refrigerated.

Preparation: 15 – 20 minutes

Nutritional analysis per serving:

Calories 115 (97% from fat) • carb. 0g • pro. 1g • fat 13g  
sat. fat 1g • chol. 27mg • sod. 4mg • fiber 0g

## Basic Vinaigrette

This basic vinaigrette is perfect for a crisp green salad.

Makes about 3/4 cup (175 ml)

1	clove garlic, peeled	1/2	teaspoon (2 ml) kosher salt
2	tablespoons (25 ml) Dijon-style mustard	1/4	teaspoon (1 ml) freshly ground pepper
		1/3	cup (75 ml) extra virgin olive oil
1/4	cup (50 ml) wine vinegar	1/3	cup (75 ml) vegetable oil

Insert the metal blade. With the machine running, drop the garlic through the feed tube and process to chop, 10 seconds. Scrape the work bowl. Add the mustard, vinegar, salt, and pepper. Process to combine, 10 seconds; scrape the work bowl. With the machine running, add the oils in a slow, steady stream, about 45 seconds. Process until emulsified. Refrigerate unused portions; bring to room temperature before using. Process for 10 seconds to emulsify if separation has occurred.

Note: Basic Vinaigrette may be modified by changing the flavour of the vinegar, mustard or oil. Try using fresh lemon juice and a little honey for a honey-mustard vinaigrette. Add fresh herbs, sun-dried tomatoes, or pesto for other flavour changes.

Preparation: 5 minutes

Nutritional analysis per tablespoon (15 ml):

Calories 110 (96% from fat) • carb. 1g • pro. 0g • fat 12 g  
sat. fat 2g • chol. 0mg • sod. 116mg • fiber 0g

## Pesto

Our pesto is lower in fat than traditional pestos, and just as flavourful.

Makes 3/4 cup (175 ml)

1	ounce (28 g) Reggiano Parmesan, cut in 1/2-inch (1.25 cm) pieces	2 to 4	tablespoons (25 to 50 ml) extra virgin olive oil
1	clove garlic	2	tablespoons (25 ml) lightly toasted pine nuts or walnuts
2	cups (500 ml) packed fresh basil leaves, washed and dried	1/4	teaspoon (1 ml) salt

Insert the metal blade. With the machine running, drop the cheese down the feed tube and process to chop, about 10 seconds. Remove and reserve. With the machine running, drop the garlic clove down the feed tube; process to chop, about 5 seconds. Scrape down the sides of the work bowl. Add the basil to the work bowl. Pulse to chop, 20 to 30 times. Scrape down the sides of the work bowl. With the machine running, add the olive oil to taste in a slow drizzle. Scrape down the sides of the work bowl, add the reserved cheese, pine nuts and salt, pulse to incorporate and chop the nuts. Transfer to a jar to store. Let rest for about 30 minutes before using, to allow the flavours to blend. Refrigerate to store, with a layer of olive oil poured over the top to prevent discolouration. Keeps 5 days in the refrigerator, or may be frozen.

Preparation: 5 to 10 minutes

Recipe analysis per 1/2 tablespoon (7 ml) serving:

Calories 25 (84% from fat) • carb. 0g • pro. 1g • fat 2g  
sat. fat 0g • chol. 1mg • sod. 29mg • fiber 0g

## Cranberry Relish with Toasted Walnuts

Fast and fresh, this relish is delicious with roast turkey, chicken, pork or ham.

Makes 2 cups (500 ml)

1/2	cup (125 ml) walnut halves	2	cups (500 ml) fresh or frozen cranberries (do not thaw if using frozen berries)
1/2	cup (125 ml) sugar		
5	strips orange zest	1/2	large navel orange, peeled, cut into quarters

Preheat oven to 350° F (177° C). Place walnuts in a baking pan and toast until golden brown and fragrant, about 8 to 10 minutes. Cool slightly.

Insert metal blade in food processor. Process sugar and zest until finely chopped, about 45 seconds. Add cranberries, orange and reserved nuts; pulse until coarsely chopped, about 10 to 12 times. Pulse several more times if a finer consistency is desired.

This relish may be made in advance and stored in the refrigerator until ready to use.

Preparation: 5 – 10 minutes

Nutritional analysis per 2 tablespoons (25 ml):

Calories 52 (29% from fat) • carb. 9g • pro. 1g • fat 2g  
sat. fat 0g • chol. 0mg • sod. 0mg • fiber 1g

## Simple Tomato Sauce

A simple marinara sauce for pasta, or when reduced, a tasty topping for homemade pizzas.

Makes 2 cups (500 ml) tomato sauce for pasta / 1-1/4 cups (300 ml) tomato sauce for pizza.

1	small onion (3 ounces [85 g] ), cut in 1-inch (2.5 cm) pieces	2	tablespoons (25 ml) dry white wine or vermouth
3/4	teaspoon (3 ml) extra virgin olive oil	1/8	teaspoon (0.5 ml) kosher salt
3	cloves garlic, peeled	1/8	teaspoon (0.5 ml) freshly ground black pepper
1/2	teaspoon (2 ml) dried oregano	1/4 – 1/2	teaspoon (1 – 2 ml) red pepper flakes (optional, to taste, for a spicier sauce)
1	can (19-ounce [539 g]) plum tomatoes, with juices		
1	sprig fresh basil (6 – 8 large leaves)		

Insert the metal blade. Pulse to chop the onion, 10 times. Heat the olive oil over medium heat in a 2-quart (1.9 L) saucepan. Add the onion, garlic, and oregano. Cook, stirring for 2 to 3 minutes, until the onions begin to soften and the oregano becomes fragrant. Add the canned tomatoes with their juices, basil sprigs, wine and salt. Bring to a boil, then reduce the heat to low, cover loosely and simmer for 50 to 60 minutes. Turn off the heat and let cool in the pan for 10 minutes. Stir in the black pepper and optional red pepper flakes.



Using the metal blade, pulse the sauce 15 times for a rustic, chunky sauce, or process for 2 minutes for a smooth sauce. The sauce is now ready to use for pasta. If you want a sauce for pizza, return the sauce to the pan. Simmer, uncovered over low heat, for 30 – 40 minutes to reduce, stirring now and then. Transfer the reduced sauce to a bowl to cool before using as a pizza topping. Simple Tomato Sauce may be frozen.

Preparation: 10 – 15 minutes, plus 1 hour to cook (add an additional 30 - 40 minutes to make the reduced Pizza Sauce).

Nutritional analysis per 1/2 cup (125 ml) serving:

Calories 55 (19% from fat) • carb. 89g • pro. 2g • fat 1g  
sat. fat 0g • chol. 0mg • sod. 339mg • fiber 2g

## Chocolate Sauce

Our Cuisinart Chocolate sauce uses fat free milk rather than the traditional heavy cream.

Makes 1-1/4 cups (300 ml) / 20 tablespoons (300 ml)

- |   |  |       |   |
|---|--|-------|---|
| 4 | ounces (113 g) good quality bitter-sweet or semi-sweet chocolate (Lindt, Callebaut, Ghirardelli), broken into 1-inch (2.5 cm) pieces | 2     | tablespoons (25 ml) superfine or bar sugar                                  |
|   |  | 1/2   | cup (125 ml) fat-free milk, heat until it is just bubbling around the edges |
| 4 | ounces (113 g) good quality milk chocolate (Lindt, Callebaut, Ghirardelli), broken into 1-inch (2.5 cm) pieces                       | 1-1/2 | teaspoons (7 ml) vanilla  |

Insert the metal blade. Pulse to chop the chocolates, 20 to 30 times. Add the sugar; process to chop finely, 45 seconds. With the machine running, pour the hot milk slowly and carefully down the feed tube; process until the chocolate is melted and smooth, 1 minute. Add the vanilla; process to combine, 10 seconds.

Serve immediately or transfer to a resealable container and refrigerate. Reheat in a double boiler or microwave to serve.

Preparation: 10 minutes

Nutritional analysis per tablespoon (15 ml):

Calories 65 (50% from fat) • carb. 8g • pro. 1g • fat 4g  
sat. fat 2g • chol. 1mg • sod. 8mg • fiber 0g

# Entrées

## East-West Chicken and Vegetable Stir-Fry with Pasta

Asian flavours blend with Italian Reggiano Parmesan and pasta in this colourful and delicious stir-fry.

Makes 4 servings

2	boneless, skinless chicken breast halves (6 – 8) ounces [170 – 227 g ] each)	1	broccoli crown, about 6 ounces (170 g) , florets cut off, stem reserved
8	ounces (227 g) dry pasta shapes such as fusilli, radiatore, penne, or double elbows	1	large carrot, about 4 ounces (113 g), peeled and cut into 1-1/2-inch (3.75 cm) lengths
1	ounce (28 g) Reggiano Parmesan cheese, cut in 1/2-inch (1.25 cm) cubes	1-1/2	teaspoons (7 ml) cornstarch
1	small clove garlic	1/4	cup (50 ml) chicken stock
3	slices peeled ginger, each about the thickness of a quarter	2-1/2	tablespoons (38 ml) Asian sesame oil, divided
1/2	red bell pepper, stem, ribs and seeds removed, cut to fit the feed tube	3	tablespoons (45 ml) sherry (Amontillado or medium-dry)
1/2	yellow bell pepper, stem, ribs and seeds removed, cut to fit the feed tube	2	tablespoons (25 ml) tamari sauce or soy (low sodium may be used)
		1/4	cup (50 ml) slivered almonds, lightly toasted

Trim the chicken of all visible fat. Cut in half crosswise; place on a baking sheet lined with plastic wrap and freeze for 20 to 25 minutes. Clean the work surface and wash hands thoroughly. Using a pasta cooking pot with insert, cook the pasta al dente in lightly salted water according to package instructions. Drain the pasta; keep the water simmering.

Insert the metal blade. With the machine running, drop the cheese cubes through the feed tube and process until finely chopped, about 30 seconds. Remove and reserve. With the machine running, drop the garlic and ginger through the feed tube and process until finely chopped, about 5 seconds. Remove and reserve.

Insert the slicing disc. Use medium pressure to slice the peppers. Remove to a plate. Using a vegetable peeler, peel the broccoli stem; trim to fit the small feed tube. Use medium pressure to slice, remove and reserve. Arrange the carrots horizontally in the large feed tube. Use medium pressure to slice, remove and reserve.

Remove the chicken from the freezer; place in the large feed tube cut side down. Use medium pressure to slice. Toss with 1 tablespoon (15 ml) of the sesame oil and set aside on a plate separate from the vegetables. Clean the work surface thoroughly, and wash hands with hot soapy water. In a small bowl, combine the cornstarch and chicken stock. Set aside.

Heat a large, nonstick stir-fry pan over high heat. When hot enough to make water droplets dance, stir-fry the chicken until opaque, about 2 to 3 minutes. Remove to a clean plate and

reserve. Add the remaining sesame oil to the pan. When hot, add the garlic and ginger, stir-fry 10 seconds. Add the sliced broccoli stems and carrots. Stir-fry for 45 seconds. Add the broccoli flowerets and sliced red bell pepper; stir-fry for another 30 seconds. Return the cooked chicken to the pan along with the soy sauce and sherry, and cook for 30 seconds. Stir in the cornstarch mixture, and bring to a boil. Return the pasta to the simmering pasta water to reheat. Drain and add to the stir-fry pan. Remove from the heat, add half the cheese and toss to coat with the sauce.

Transfer the stir-fry to a warmed serving bowl. Top with the remaining cheese and the toasted almonds. Serve immediately.

Preparation: 30 minutes

Nutritional analysis per serving:

Calories 528 (26% from fat) • carb. 59 • pro. 40g • fat 15g  
sat. fat 3g • chol. 71mg • sod. 541g • fiber 6g

## Salmon and Pesto Potatoes

Just add a simple green salad for a quick and easy dinner.

Makes 4 servings

1	tablespoon (15 ml) extra virgin olive oil	1-1/4	pounds (567 g) boneless, skinless salmon fillet, cut in 5-ounce (142 g) portions
4	Yukon Gold or other new potatoes, 4 ounces (113 g) each, well scrubbed, opposite ends trimmed flat with a knife	1/2	teaspoon (2 ml) kosher salt
		1/4	teaspoon (1 ml) freshly ground pepper
4	teaspoons (20 ml) Pesto, p. 30	4	fresh basil leaves

Preheat the oven to 400° F (204° C). Cut 4 pieces of aluminum foil, each 16 inches (40 cm) long.

Brush a 4 x 6-inch (10 x 15 cm) area in the centre of each rectangle with olive oil. Set aside.

Insert the slicing disc. Slice the potatoes, one at a time; remove each potato, restack and reserve separately. Blanch potatoes in boiling water for 3 – 4 minutes. Drain and let cool.

Season each salmon fillet with salt and pepper. Fan out the slices of one potato on the oiled portion of a sheet of foil. Spread one teaspoon (5 ml) of the Pesto on the fanned slices. Top with a salmon fillet. Bring the two cut sides of the foil together over the centre of the salmon, fold over 1 inch (2.5 cm), then fold over 2 more times. Fold the ends in twice, in 1/2-inch (1.25 cm) folds, to complete the seal. Repeat until all the salmon and potatoes have been prepared and wrapped. Bake in the preheated oven for 18 minutes. While the salmon is in the oven, stack the basil leaves and roll. Slice in 1/8-inch (0.31 cm) intervals to create a chiffonade. The packets will be puffed; prick with the tip of a sharp knife to vent the steam, then carefully open. Serve immediately on warmed plates sprinkled with the basil chiffonade.

Preparation: 10 – 15 minutes, plus 18 minutes baking time

Nutritional analysis per serving:

Calories 367 (31% from fat) • carb. 27g • pro. 34g • fat 12g  
sat. fat 2g • chol. 72mg • sod. 266mg • fiber 2g

## Hearty Turkey Chili – Cincinnati Style

Try our heart-smart variation of Cincinnati-Style chili. When served with cooked spaghetti, kidney beans, chopped onion, grated Cheddar cheese, and oyster crackers it is known as “Five Way Chili.”

If you prefer beef chili, you can use beef chuck rather than turkey.

Makes 4 servings (served alone); 6 when served Cincinnati style

1	bell pepper, cored and seeded, cut in eighths	1/2	teaspoon (2 ml) oregano
2	cloves garlic, peeled	1/2	teaspoon (2 ml) ground allspice
1/2	pound (227 g) onions, peeled, cut into 1-inch (2.5 cm) pieces	1/2	teaspoon (2 ml) ground cinnamon
1-1/4	pounds (567 g) boneless, skinless turkey breast, cut into 1-inch (2.5 cm) pieces	1	small bay leaf
1	tablespoon (15 ml) good quality olive oil	1-1/2	cups (375 ml) canned crushed tomatoes
2	tablespoons (25 ml) chili powder	1/4	cup (50 ml) tomato paste, salt-free if available
1	teaspoon (5 ml) ground cumin	1-1/2	cups (375 ml) chicken stock /broth (low sodium, no fat)
1/2	teaspoon (2 ml) ground coriander	1-1/2	cup (375 ml) water
		2	teaspoons (10 ml) wine vinegar
		1/2	teaspoon (2 ml) kosher salt

Insert the 4 mm slicing disc; use medium pressure to slice the peppers, then remove and reserve. Insert the metal blade. With the machine running, drop the garlic through the small feed tube and process to chop, 10 seconds. Scrape the work bowl. Add the onions; pulse to chop, 10 to 12 times. Remove and reserve.

Add half the turkey cubes to the work bowl; pulse to chop, 10 to 12 times. Remove and reserve; repeat with the remaining turkey cubes.

In a large saucepot, heat half the oil over medium heat until shimmering. Sauté the garlic and onions until tender and lightly browned, about 5 minutes. Stir in the chili powder, cumin, coriander, oregano, allspice, cinnamon and bay leaf, cook until fragrant, about 5 minutes. While the onion mixture is cooking, in a 12-inch (30 cm) nonstick skillet, heat the remaining oil over medium high heat and brown the turkey. Do not turn until nicely browned; break up after turning. As the turkey is cooked, add it to the onion mixture. When all the meat has been added, stir in the reserved bell peppers, crushed tomatoes, tomato paste, chicken stock, water, vinegar, and salt. Cover loosely and bring to a boil. Reduce the heat to low, and simmer the chili for 2-1/2 hours, until the meat is tender and the mixture thickens.

Serve plain, or Cincinnati style.

Preparation: 30 minutes, plus 2-1/2 hours to cook

Nutritional analysis per serving:

Calories 302 (16% from fat) • carb. 20g • pro. 43g • fat 5g  
sat. fat 1g • chol. 106mg • sod. 701mg • fiber 5g

# Pizza

## Pesto, Cheese & Fresh Tomato Pizza

Homemade pesto and fresh, ripe tomatoes make this a great summertime pizza.

Makes one 14-inch (35 cm) pizza or two 9-inch (22.5 cm) pizzas, to serve 4

Pizza Dough, p. 27	1-1/2 ounces (43 g) Italian fontina cheese, very well chilled
1/2 pound (227 g) firm but ripe plum tomatoes	3 tablespoons (45 ml) pesto, p. 30
1/2 ounce (14 g) Reggiano Parmesan, cut in 1/2-inch (1.25 cm) cubes	1 teaspoon (5 ml) extra virgin olive oil
2 ounces (57 g) fresh mozzarella, very well chilled	Cornmeal for dusting the peel or pan

Prepare the Pizza Dough and let rise. Position the top rack of the oven about 8 inches (20 cm) from the top. If using a baking stone, place it on the rack. Preheat the oven to 500° F (260° C).

Bring 6 cups (1.5 L) of water to a boil in a medium saucepan. Cut a shallow “x” in the bottom of each tomato. Blanch the tomatoes in the boiling water for 30 seconds, then immediately plunge them into a bowl of iced water. When cool, slip the skins off. Slice the stem end off each tomato; set aside.

Insert the metal blade. With the machine running, drop the Parmesan cheese cubes down the feed tube. Process 15 seconds; leave in bowl. Insert the shredding disc. Use medium pressure to shred the mozzarella and fontina. Remove the cheeses to a bowl; toss to combine and reserve. Insert the slicing disc. One at a time, place the tomatoes in the small feed tube. Use very light pressure to slice. Place the sliced tomatoes on a triple thick layer of paper towels to drain.

When the dough has risen, punch down, use as is or divide into 2 equal balls. Let rest 10 minutes. Roll the dough out to size. Place on a baker’s peel that has been sprinkled with corn meal, or on a perforated pizza pan, a pizza screen or baking sheet without sides that has been sprinkled with corn meal. Brush the edges with the olive oil, then using an offset spatula, spread the pizza to 3/4-inch (1.88 cm) of the edges with the pesto sauce, using 3 tablespoons (45 ml) on the 14-inch (35 cm) pizza and 1-1/2 tablespoons (25 ml) on each 9-inch (22.5 cm) pizza. Sprinkle the pizza(s) with the shredded cheeses. Top with the drained, sliced tomatoes.

Carefully slide the pizza onto the stone (position the peel over the back edge of the stone, and use a rocking motion to shake and slide the pizza off the peel onto the stone), or place the pan into the hot oven. Bake the pizza for 5 minutes, then rotate it front to back for even baking. Bake for another 3 to 6 minutes, until the pizza is bubbly, and the edges of the dough are golden brown, puffed and crispy. Remove from the oven and let rest on a rack for 2 to 3 minutes before slicing.

Preparation: 1 hour for the pizza dough (Cuisinart recipe, p. 27); then 20 minutes plus 12 minutes to bake

Nutritional analysis per serving:

Calories 365 (from fat 33%) • carb. 46g • pro. 15g • fat 13g  
sat. fat 5g • chol. 21mg • sod. 678mg • fiber 2g

# Sides

## French Cut Green Beans with Shallots

“French cut” green beans take just seconds with the Cuisinart® DLC-2007C.

Makes 4 servings

1	pound (454 g) fresh green beans, trimmed, cut to fit feed tube horizontally	1/4	cup (50 ml) water
		1-1/2	teaspoons (7 ml) balsamic vinegar *
2	large shallots, peeled, cut into 1-inch (2.5 cm) pieces	1/8	teaspoon (0.5 ml) white pepper
		1/8	teaspoon (0.5 ml), kosher salt
2	teaspoons (10 ml) olive oil		

Insert 4 mm slicing disc in food processor. Place beans horizontally in large feed tube and process using light pressure. Remove and reserve.

Insert metal blade. Process shallot until finely chopped, about 5 seconds.

Warm oil in a 3-1/2-quart (3.3 L) sauté pan over medium heat. Add chopped shallots and sauté until soft but not browned, about 2 minutes. Add green beans and sauté for 3 to 4 minutes. Add water and reduce heat to low. Cover pan and cook until crisp tender, about 8 to 10 minutes. Remove from heat and add vinegar. Season with pepper and salt. Serve warm.

\*Substitute a fruit-flavoured vinegar for a change.

Preparation: 15 minutes

Nutritional analysis per serving:

Calories 66 (31% from fat) • carb. 11g • pro. 2g • fat 3g  
sat. fat 0g • chol. 0mg • sod. 46mg • fiber 4g

## Savoury Sweet Potatoes with Onions & Currants

A low-fat alternative to traditional, rich sweet potato casseroles.

Makes 6 servings

Cooking spray	2	strips orange zest (2 x 1/2-inch [5 x 1.25 cm]), bitter white pith removed	
2	ounces (57 g) fresh white or wheat bread		
3	tablespoons (45 ml) unsalted butter, at room temperature, divided	1/2	cup (125 ml) freshly squeezed orange juice
2	pounds (907 g) sweet potatoes, peeled and cut in half crosswise	1/2	cup (125 ml) maple syrup (do not use pancake syrup)
3/4	pound (340 g) yellow onions, peeled and cut in half lengthwise	3/4	teaspoon (3 ml) herbs de Provence
		1/2	teaspoon (2 ml) kosher salt
1/3	cup (75 ml) currants	1/4	teaspoon (1 ml) freshly ground pepper

Preheat the oven to 350° F (177° C). Spray an 8 x 8 x 2-inch (20 x 20 x 5 cm) pan (8 cup [2 L]) with cooking spray. Set aside.

Insert the metal blade. Process the bread until it becomes coarse crumbs, 15 to 20 seconds. With the machine running, drop 1 tablespoon (15 ml) of the butter through the feed tube and process 10 seconds to blend with the crumbs. Remove and reserve.

Insert the slicing disc. Arrange the sweet potatoes in the feed tube cut side down; use medium pressure to slice. Remove and reserve. Arrange the onions in the feed tube. Use medium pressure to slice. Remove and reserve. Wipe the work bowl dry with a paper towel. Insert the metal blade. Use the pulse to chop the orange zest, about 15 to 20 times. Scrape the work bowl. Add the orange juice, maple syrup, herbs de Provence, salt, pepper, and remaining butter. Process to combine, 5 seconds.

Arrange one third of the sliced sweet potatoes in a layer in the prepared pan. Top with half the onions and half the currants. Repeat and end with a layer of sweet potatoes. Drizzle the orange juice mixture evenly over the entire casserole. Cover loosely with a sheet of foil that has been sprayed with cooking spray. Bake in the preheated oven for 65 to 75 minutes, until the potatoes are tender. Remove the foil, sprinkle evenly with the reserved breadcrumb mixture and bake 10 minutes longer. Let rest 10 minutes before serving.

Preparation: 15 – 20 minutes, plus 85 minutes baking and resting.

Nutritional analysis per serving:

Calories 269 (18% from fat) • carb. 64g • pro. 5g • fat 4g  
sat.fat 4g • chol. 16mg • sod. 182mg • fiber 2g

## Asian Slaw with Peanut Dressing

Add cooked pasta and turn this salad into a meal.

Makes 3/4 cups (175 ml) dressing

Makes 6 cups (1.5 L) Asian Slaw

1/4	cup (50 ml) toasted unsalted peanuts	1	small broccoli spear, washed, florets trimmed and reserved, stem peeled
1	clove garlic		
4	slices of fresh ginger, peeled, each about the size of a quarter	2	green onions, trimmed, cut to fit feed tube
3	tablespoons (45 ml) peanut butter (regular or chunky)	1	small (4 ounce [113 g]) red bell pepper, stemmed, seeded, quartered
1/3	cup (75 ml) rice vinegar	1	small yellow bell pepper, stemmed, seeded, quartered
2-1/2	teaspoons (12.5 ml) sugar	6	ounces (170 g) Napa cabbage, washed, cut to fit feed tube
1-1/2	tablespoons (25 ml) hoisin sauce	6	ounces (170 g) bok choy, washed, cut to fit feed tube (include leafy greens if tender)
2	teaspoons (10 ml) Asian (toasted) sesame oil	6	ounces (170 g) bok choy, washed, cut to fit feed tube (include leafy greens if tender)
1-1/4	teaspoons (6 ml) low-sodium tamari or soy sauce	3	ounces (85 g) snow peas or sugar snap peas, trimmed and strings removed
4-6	red radishes (3 ounces [85 g]), washed and trimmed		
1	carrot (3 – 4 ounces [85 – 113 g]), peeled, cut to fit the feed tube horizontally		

Insert the metal blade. Pulse to chop the peanuts, about 10 times. Remove and reserve. With the machine running, drop the garlic and ginger down the feed tube to chop, about 5 seconds. Scrape the work bowl; process 5 seconds longer. Add the peanut butter, sugar, rice vinegar, hoisin sauce, and tamari. Process until smooth, about 10 seconds. Scrape down the sides of the work bowl. With the machine running, add the sesame oil in a steady stream through the feed tube; process until emulsified, about 10 to 15 seconds. Remove and reserve. The dressing may be made several days ahead. Cover well and refrigerate. Let sit for 30 minutes at room temperature before using.

Clean the work bowl. Insert the shredding disc. Arrange the radishes in the feed tube cut side down. Use medium pressure to shred. Arrange the carrots horizontally in the feed tube. Use medium pressure to shred. Insert the trimmed and peeled broccoli stem in the small feed tube; use medium pressure to shred. Transfer the shredded vegetables and reserved broccoli florets to a large bowl. Insert the slicing disc. Arrange the green onions in the small feed tube. Use light pressure to slice. Arrange the peppers in the large feed tube, cut side down; use medium pressure to slice. Arrange the Napa cabbage in the feed tube, cut side down. Use medium pressure to slice. Arrange the bok choy in the feed tube; use medium pressure to slice. Transfer the sliced vegetables to the bowl with the other vegetables. Add the snow peas and toss the vegetables to combine. Pour the dressing over the vegetables and toss to coat well. Garnish with reserved chopped peanuts.

Note: You may turn this into an Asian pasta salad by doubling the dressing ingredients and adding cooked pasta (6 ounces [170 g] dry, cooked according to package directions).

Preparation: 10 minutes plus 30 minutes resting time for the dressing; 10 – 15 minutes for the vegetables.

Nutritional analysis per serving:

Calories 125 (45% from fat) • carb. 18g • pro. 6g • fat 9g  
sat. fat 1g • chol. 0mg • sod. 534mg • fiber 3g

## Creamy Tarragon Vidalias

Serve alongside a roasted tenderloin of beef.

Makes 3 cups (750 ml)

3/4	cup (175 ml) water	1/2	cup (125 ml) drained nonfat plain yogurt *
1/3	cup (75 ml) sugar	1/4	cup (50 ml) mayonnaise, p.29, or purchased (mayonnaise lowfat)
1/3	cup (75 ml) rice wine vinegar	1	teaspoon (5 ml) dried tarragon
1-1/2	pounds (680 g) Vidalia onions, or any other sweet onion such as WallaWalla, Oso, Rio, Maui, or Texas 1015, peeled and cut in half vertically	1/4	teaspoon (1 ml) kosher salt
		1/8	teaspoon (0.5 ml) white pepper

In a small non-aluminum saucepan, bring the water, sugar and rice wine vinegar to a boil. Boil until the sugar has dissolved. Remove from the heat and allow to cool.

Insert the medium slicing disc. Arrange the onions flat side down in the large feed tube and process to slice. Remove to a large glass bowl, and toss with the cooled sugar and vinegar mixture. Cover and refrigerate for 24 hours, turning the onions every few hours.

Drain the onions and squeeze dry. Discard the soaking liquid.



Insert the metal blade. Process the drained yogurt, mayonnaise, tarragon, salt and pepper until smooth, about 10 seconds. Add to drained onions and toss to combine well. Cover and refrigerate at least 30 minutes before serving to allow flavours to develop.

\*To drain yogurt: Line a sieve with a double layer of cheesecloth or a paper coffee filter and set over a bowl. Place yogurt in sieve; cover and refrigerate at least 8 hours or overnight. You may need to drain water from bowl occasionally. Refrigerate thickened yogurt in an airtight container for up to one week. The thickened yogurt will be approximately half its original volume in 24 hours.

Preparation: 10 minutes, plus 24 hours to marinate the onions and drain the yogurt

Nutritional analysis per quarter cup (50 ml) (prepared with lowfat mayonnaise):

Calories 49 (32% from fat) • carb. 7g • pro. 2g • fat 2g  
sat. fat 0g • chol. 2mg • sod. 87mg • fiber 0g

## Roasted Garlic and Parmesan Twice Baked Potatoes

These “dressed up” twice-baked potatoes go well  
with grilled London broil or fillets.

Makes four servings

6	garlic cloves, peeled	2	green onions, trimmed, cut into 1-inch (2.5 cm) pieces
	Olive oil		
4	large baking potatoes (about 8 ounces [227 g] each), washed, pierced with a knife	1/2	cup (125 ml) evaporated skim milk
		2	tablespoons (25 ml) unsalted butter, cut into 4 pieces
1-1/2	ounces (43 g) Reggiano Parmesan cheese, cut into 1-inch (2.5 cm) pieces	1/4	teaspoon (1 ml) ground white pepper
		1/4	teaspoon (1 ml) kosher salt

Preheat oven to 400° F (204° C). Place garlic cloves in a small ovenproof ramekin and drizzle with olive oil. Cover with aluminum foil. Lightly brush potatoes with olive oil. Place garlic and potatoes in preheated oven; roast garlic for 30 to 40 minutes and bake potatoes until fork tender, about 1 hour. When cool enough to handle, cut off part of top of potato and scoop out flesh leaving a 1/4-inch (35 cm) thick shell. Reserve flesh and skins.

Insert metal blade. With machine running, drop cheese through small feed tube and process until finely grated, about 30 seconds; reserve. Place scallions in work bowl and process until finely chopped, about 5 to 10 seconds. Scrape work bowl. Add garlic, milk, butter, reserved cheese, pepper and salt. Process until combined, about 12 seconds. Add potato flesh; pulse in very short quick pulses until just combined, about 10 to 12 times. Scrape bowl and pulse in very short quick pulses, about 10 more times. Generously fill potato shells with potato-garlic mixture. Potatoes may be made ahead to this point and refrigerated until ready to bake.

Preheat oven to 350°F (177°C). Place potatoes in a 9-inch (22.5 cm) square baking pan and bake, uncovered, until tops are golden brown and potatoes are hot, about 20 to 25 minutes. (Add 5 to 10 minutes to baking time if the potatoes are cold from the refrigerator.)

Preparation: 10 – 15 minutes (allow 1 hour to prebake potatoes), plus 25 minutes to twice bake

Nutritional analysis per serving:

Calories 341 (24% from fat) • carb. 55g • pro. 11g • fat 9g  
sat. fat 5g • chol. 23mg • sod. 266mg • fiber 4g

# Desserts

## Toffee Brownies

Our sinfully delicious brownies just melt in your mouth.

Makes 16 servings

	Cooking spray	2	large eggs
2	ounces (57 g) unsweetened baking chocolate, broken into 1/2 - inch (1.25 cm) pieces	1	teaspoon (5 ml) vanilla extract
		1/2	cup (125 ml) all-purpose unbleached flour
1	cup (250 ml) sugar	3/4	cup (175 ml) almond toffee bits (such as Heath® brand)
1/2	cup (125 ml) unsalted butter, melted		

Preheat oven to 350° F (177° C). Lightly coat an 8 x 8-inch (20 x 20 cm) baking pan with vegetable oil cooking spray. Line pan with foil, allowing two sides to overlap pan for easy removal from pan. Lightly coat foil lining with vegetable oil cooking spray.

Insert metal blade. Process chocolate until coarsely chopped, about 20 to 25 seconds. Add sugar and process until chocolate is as fine as the sugar, about 45 seconds. With unit running, pour melted butter through the small feed tube and process until blended, about 20 to 25 seconds. Scrape work bowl. Add eggs and vanilla; process until fluffy and light, about 10 to 15 seconds. Add flour and toffee bits; pulse until just combined, about 5 to 6 times. Do not overprocess. Spread in prepared pan. Bake until top of brownies looks set and a toothpick inserted in the centre comes out almost clean, about 25 to 30 minutes. (Due to the fudgy nature of the brownies, the toothpick will not be completely clean.) Cool in pan for 15 minutes. Use foil overhangs to remove from pan and let cool completely before slicing. Cut into 16 squares.

Preparation: 10 minutes, plus 30 minutes to bake.

Nutritional analysis per Brownie:

Calories 202 (52% from fat) • carb. 23g • pro. 2g • fat 12g  
sat. fat 6g • chol. 46mg • sod. 69mg • fiber 1g

## Double Chocolate Chunk Cookies

Chocolate heaven!

Makes 24 cookies

4	ounces (113 g) milk chocolate, chilled, broken into 1-inch (2.5 cm) pieces	1/4	teaspoon (1 ml) salt
		1	large egg
4	ounces (113 g) white chocolate, chilled, broken into 1-inch (2.5 cm) pieces	6	tablespoons (90 ml) firmly packed light brown sugar
		6	tablespoons (90 ml) sugar
1	cup (250 ml) plus 2 tablespoons (25 ml) all-purpose unbleached flour	4	tablespoons (50 ml) unsalted butter, softened
1/3	cup (75 ml) pecan halves	2-1/4	teaspoons (11.25 ml) vanilla extract
1/2	teaspoon (2 ml) baking soda		

Preheat oven to 375° F (191° C).

Insert the metal blade and add chocolates. Use quick pulses to coarsely chop, about 10 to 12 times. Remove and reserve. Add flour, pecans, soda and salt; process to combine, about 5 seconds. Remove and reserve.

Process egg and sugars for 1 minute. Scrape work bowl. Add butter and vanilla; process for 1 minute. Scrape work bowl. Add reserved chocolate and dry ingredients. Pulse until combined, about 5 times.

Drop by rounded tablespoons (15 ml), about 1 inch (2.5 cm) apart, onto ungreased, nonstick baking sheets. Bake until golden brown, about 10 to 12 minutes. Let cool on baking sheet for 5 minutes, then transfer to a wire rack to finish cooling.

Preparation: 10 to 15 minutes, plus 20 to 25 minutes to bake and cool

Nutritional analysis per cookie:

Calories 133 (45% from fat) • carb. 17g • pro. 2g • fat 7g  
sat. fat 3g • chol. 17mg • sod. 61mg • fiber 0g

## Dark Chocolate Ganache Truffles

A chocolate lover's dream come true.

Makes 1-1/4 cups (300 ml) ganache / 20 truffles

1/4	cup (50 ml) unsweetened Dutch-process cocoa	1/2	cup (125 ml) heavy cream
9	ounces (255 g) good quality bitter-sweet or semi-sweet chocolate such as Lindt, Ghirardelli, or Callebaut, broken into 1-inch (2.5 cm) pieces, chilled	1-1/2	tablespoons (25 ml) unsalted butter
		2	tablespoons (25 ml) brandy or other liqueur
		1	tablespoon (15 ml) vanilla

Insert the metal blade. Pulse to sift the cocoa; remove and reserve. Pulse to finely chop the chocolate, 20 to 30 times. Heat the cream in a saucepan or in the microwave until it is just bubbling at the edges. Stir in the butter. With the machine running, pour the mixture down the feed tube and process until the mixture is smooth, about 1 minute. Scrape the sides and bottom of the work bowl. With the machine running, add the brandy and vanilla; process to incorporate, about 10 seconds. Transfer the mixture to a small bowl. Cover with a piece of plastic wrap directly on the chocolate. Refrigerate until firm.

Divide the ganache into 20 equal portions. Shape into imperfect balls. Refrigerate 30 minutes. Dip the balls into the cocoa to coat. Refrigerate for up to a week, or freeze for a month well wrapped. If necessary, redust the truffles in cocoa.

Preparation: 10 – 15 minutes, plus 2 - 3 hours to chill, and 15 – 20 minutes to shape and dust the truffles.

Nutritional analysis per truffle:

Calories 97 (66% from fat) • carb. 8g • pro. 1g • fat 8g  
sat. fat 4g • chol. 10mg • sod. 3mg • fiber 1g

## Basic Cheesecake

Creamy, smooth and simple to prepare. Top with fresh fruit for a special dessert.

Makes 6 servings

3	lowfat honey graham crackers, broken into pieces	1/2	cup (125 ml) sugar
		1	tablespoon (15 ml) vanilla
1	tablespoon (15 ml) sugar	2	large eggs, at room temperature
1	tablespoon (15 ml) unsalted butter		
1	pound (454 g) lowfat cream cheese, at room temperature		

Preheat the oven to 325° F (163° C). Wrap the bottom and sides of a 7 x 3-inch (17.5 x 7.5 cm) springform pan in a sheet of oversized aluminum foil. There should be no seams in the foil, and it should come up to the top of the pan. Cut off any excess.

Insert the metal blade. Process the graham crackers until they are fine crumbs; add the sugar and the butter through the feed tube and process until the butter can no longer be seen. Press into the bottom of the prepared pan. Put in the freezer until ready to fill.

Wipe out the work bowl with a paper towel. Insert the metal blade. Process the cream cheese until smooth, about 20 to 30 seconds. Add the sugar and vanilla through the feed tube and process until smooth, about 30 seconds. Scrape down the sides of the work bowl. With the machine running, add one egg; process to incorporate, about 5 to 10 seconds; scrape down the sides of the work bowl. Add the second egg; process to incorporate, 5 to 10 seconds; scrape the work bowl; process for 5 seconds longer. Do not overprocess.

Carefully pour the cream cheese mixture into the prepared pan. Place in a roasting pan, and set on the rack of the oven. Carefully add hot water to the roasting pan until it reaches halfway up the sides of the springform pan. This is called a water bath or bain marie. Bake the cheesecake in the preheated oven for 60 minutes. The cheesecake will still look jiggly in the centre. (Do not worry – it will firm up as it cools.) Remove the cheesecake from the bain marie, remove the foil, and place on a rack. Cool completely on a rack, then cover and refrigerate for at least 8 hours.

The cheesecake is best made a day ahead. Garnish with fresh fruit if desired.

Preparation: 10 to 15 minutes, plus 1-1/2 hours baking and cooling time.

Nutritional analysis per serving:

Calories 317 (49% from fat) • carb. 30g • pro. 11g • fat 17g  
sat. fat 10g • chol. 103mg • sod. 500mg • fiber 0g

## Carrot Cake

Wonderful as a 2-layer cake, but try it as a single layer cake, freezing the second layer for another time.

Makes 8 servings

3/4	pounds (340 g) carrots peeled	1-1/2	teaspoons (7 ml) vanilla
1-1/2	cups (375 ml) all-purpose flour	3/4	cup (175 ml) pecans or walnuts, lightly toasted (3 ounces [85 g])
1	teaspoon (5 ml) baking powder	1/2	cup (125 ml) golden raisins
1/4	teaspoon (1 ml) baking soda	3/4	cup (175 ml) well drained pineapple chunks (juice packed)
1/8	teaspoon (0.5 ml) salt	3/4	pound (340 g) lowfat cream cheese
1	teaspoon (5 ml) cinnamon	4	ounces (113 g) white chocolate, such as Lindt or Callebaut, not imitation white coating
3/4	teaspoon (3 ml) ginger	16	toasted pecan or walnut halves
1/4	teaspoon (1 ml) freshly grated nutmeg		
1	cup (250 ml) brown sugar, packed		
1/4	cup (50 ml) vegetable oil		
2	large eggs		

Preheat the oven to 350° F (177° C). Spray two 8 x 2-inch (20 x 5 cm) round cake pans (6 cups [1.5 L] each) with cooking spray; line the bottom with a round of waxed paper or parchment paper and spray again. Set aside.

Insert the shredding disc; use medium pressure to shred the carrots. Divide carrots in half. Steam half the carrots until tender, about 6 to 8 minutes. Reserve the remaining raw carrots.

Insert the metal blade. Pulse the flour, baking powder, baking soda, salt, cinnamon, ginger and nutmeg to quick sift. Remove and reserve. Process the steamed carrots until smooth, 10 to 15 seconds. Add the brown sugar and oil; process until smooth, 10 seconds. Add the eggs one at a time, processing 10 seconds after each addition. Add the vanilla; process to combine, 5 seconds; scrape the bottom and sides of the work bowl. Add the flour mixture; pulse to incorporate, about 10 times. Add the pecans, raisins and pineapple. Pulse until just combined

Divide the batter evenly between the two prepared pans. Bake in the preheated 350° F (177° C) oven for 30 to 35 minutes, until a cake tester comes out clean when inserted in the centre. Cool in the pans for 10 minutes, then invert onto a wire cooling rack and remove the waxed or parchment paper. Cool completely before frosting. This cake is actually better when made a day ahead. The layers may also be well wrapped and frozen. Frost with the White Chocolate Cream Cheese Frosting and garnish with pecan halves.

### White Chocolate Cream Cheese Frosting:

Insert the metal blade. Process the cream cheese until smooth. In a double boiler over hot water, carefully melt the white chocolate – do not stir, or the chocolate will seize. With the machine running, pour the melted chocolate down the feed tube and process until smooth. This will make enough frosting to frost the layers and sides of the carrot cake. Use an offset spatula to frost the cake.

Preparation: 20 – 25 minutes, plus 2 hours to bake and cool; 30 minutes to prepare frosting and assemble the cake

Nutritional analysis per serving:

Calories 610 (45% from fat) • carb. 75g • pro. 11g • fat 31g  
sat. fat 10g • chol. 73mg • sod. 444mg • fiber 4g

## Basic Flaky Pastry Dough

This recipe makes ample crust for a 9 to 11-inch (22.5 to 27.5 cm) regular or deep-dish pie or tart. Leftover pastry may be rolled out and cut into shapes to garnish the pie, or brushed with milk, sprinkled with sugar or cinnamon and sugar, and baked until lightly browned.

For a single crust pie or tart:	For a double crust pie:
1-1/2 cups (375 ml) all-purpose flour	3 cups (750 ml) all-purpose flour
1/4 teaspoon (1 ml) salt	1/2 teaspoon (2 ml) salt
1/8 teaspoon (0.5 ml) baking powder	1/4 teaspoon (1 ml) baking powder
8 tablespoons (125 ml) unsalted butter, cut in 1/2-inch (1.25 cm) pieces, well chilled	16 tablespoons (250 ml) unsalted butter, cut in 1/2-inch (1.25 cm) pieces, well chilled
2 tablespoons (25 ml) vegetable shortening (Crisco), cut in 1/2-inch (1.25 cm) pieces, well chilled	2 tablespoons (25 ml) vegetable shortening, cut in 1/2-inch (1.25 cm) pieces, well chilled
2 to 4 tablespoons (25 to 50 ml) ice water	5 to 8 tablespoons (75 to 125 ml) ice water

Insert the metal blade. Process the flour, salt and baking powder to sift, 10 seconds. Add the well-chilled butter and shortening. Use short rapid pulses until the mixture resembles coarse corn meal and no pieces of butter larger than a “pea” remain visible, 15 to 20 pulses. Sprinkle half the maximum ice water on the flour and butter mixture, then pulse 5 or 6 times. The dough will be crumbly, but should begin to hold together when a small amount is picked up and pressed together. Sprinkle on more water, a teaspoon (5 ml) (two [10 ml] for the two-crust recipe) at a time, with 2 to 3 quick pulses after each addition, adding just enough water for the dough to hold together easily when pressed into a ball. Add the liquid sparingly so that the dough is not sticky. Do not overprocess or the pastry will be tough, not tender and flaky.

Turn the dough out onto a lightly floured surface. Press together into a ball, then flatten into a disc about 6 inches (15 cm) in diameter (two discs for the two-crust recipe). Wrap in plastic wrap and refrigerate for 1 hour before continuing to allow the gluten in the flour to rest. The dough will keep refrigerated for up to 3 days, or may be frozen (double wrapped) for up to a month. Thaw at room temperature for an hour before using.

To bake the pastry blind for a single crust filled pie or tart, roll out pastry 1/8-inch (0.31 cm) thick to fit pan; crimp and seal edges. Prick bottom all over with a fork. Chill for 30 minutes. Preheat the oven to 400° F (204° C). Line with a sheet of aluminum foil or parchment paper and fill with pie weights, dry rice or beans. Bake for 15 minutes.

Preparation: 5 – 10 minutes, plus 30 minutes to rest

Nutritional analysis per serving (single crust-double for 2 crusts):

Calories 143 (62% from fat) • carb. 12g • pro. 2g • fat 10g  
sat. fat 5g • chol. 21mg • sod. 55mg • fiber 0g

## Deep Dish Pear and Apple Pie

Pears and apples combine to make a delightful taste combination.  
You may also choose to use all pears or all apples.

Makes a 10-inch (25 cm) deep dish pie - 12 servings

	Pastry for a 2-crust pie, p.45	4	tablespoons (50 ml) unbleached all-purpose flour
3	ripe but firm pears, about 8 ounces (227 g) each, peeled, cored and quartered	3/4	cup (175 ml) dried cranberries (or dried tart cherries, dried blueberries, or raisins)
3	Granny Smith Apples, about 8 ounces (227 g) each, peeled, cored and quartered	1/4	cup (50 ml) real maple syrup (not pancake syrup)
	Juice of 1 lemon + 1 tablespoon (15 ml) freshly squeezead lemon juice	1-1/2	teaspoons (7 ml) vanilla

Preheat the oven to 400° F (204° C).

Roll out half the pastry to fit a 10-inch (25 cm) deep-dish pie plate, leaving a 1/2-inch (1.25 cm) overhang. Refrigerate until ready to use.

Insert the slicing disc. Arrange the pear quarters in the feed tube. Use medium pressure to slice. Repeat until all the pears are sliced. Transfer to a bowl and toss gently with the juice of half the lemon. Reserve. Arrange the apple quarters in the feed tube. Use medium pressure to slice. Transfer to a bowl and toss with the juice of half the lemon. Insert the metal blade. Process the remaining lemon juice, maple syrup and vanilla to combine.

Layer half the apples in the prepared piecrust; sprinkle with 1 tablespoon (15 ml) of the flour and 3 tablespoons (45 ml) of the dried cranberries. Top this with a layer of half the pears sprinkled with 1 tablespoon (15 ml) of the flour and 3 tablespoons (45 ml) of the dried cranberries. Repeat both layers. Drizzle the maple syrup mixture evenly over the top of the fruit. Roll out the remaining piecrust about 1/8-inch (0.31 cm) thick to fit the pie plate. Brush the edges of the bottom crust with a little water. Carefully lay the top crust on the pie. Press gently to seal. Trim to the edge of the pie plate; crimp or flute decoratively. Make about 10 to 12 slits in the top crust decoratively with the tip of a very sharp knife. If desired, roll out some of the leftover crust and cut with small decorative cookie cutters. For this pie, you could use pears, apples and leaves. Brush the bottoms of the shapes with a little water and lay atop the crust in a decorative fashion.

Bake the pie in the bottom third of the preheated oven for 60 to 70 minutes, covering the edges with foil if they begin to get too browned after about 35 to 40 minutes. Let the pie rest on a cooling rack at least an hour before serving.

Preparation: 15 – 20 minutes (plus time to prepare pastry crust), 2 – 3 hours to bake and cool

Nutritional analysis per serving:

Calories 366 (48% from fat) • carb. 44g • pro. 4g • fat 20g  
sat. fat 11g • chol. 41mg • sod. 112mg • fiber 4g

# Cuisinart®

SAVOR THE GOOD LIFE®



Coffeemakers



Food Processors



Toaster Ovens



Blenders



Cookware



Ice Cream  
Makers

Cuisinart offers an extensive assortment of top quality products to make life in the kitchen easier than ever. Try some of our other countertop appliances and cookware, and Savor the Good Life™.

**[www.cuisinart.ca](http://www.cuisinart.ca)**

© 2004 Cuisinart  
Cuisinart® is a registered trademark of  
Cuisinart Canada  
156 Parkshore Drive  
Brampton, Ont. L6T 5M1  
Consumer Call Centre E-mail:  
[Consumer\\_Canada@Conair.com](mailto:Consumer_Canada@Conair.com)  
Printed in China  
03CC18137

**IB-5053-CAN**